

The Future of Commerce Trend Report

2022

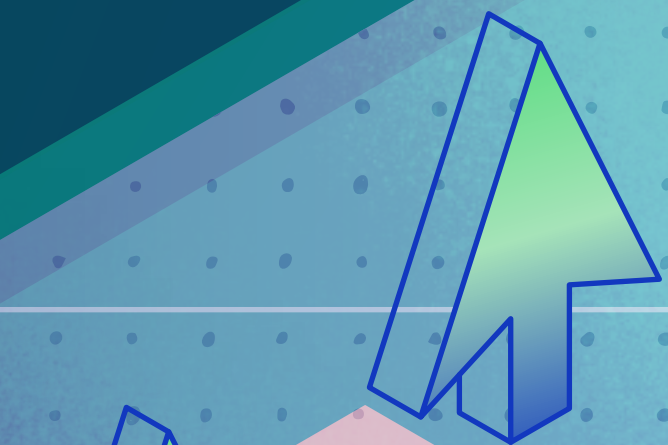
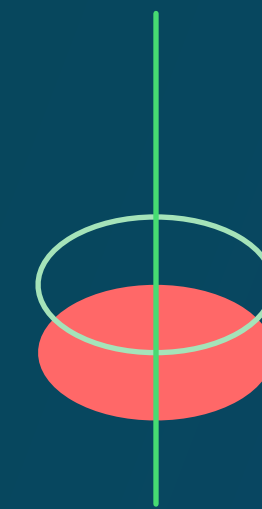

CONTENTS

Your roadmap to the future of commerce 04

Chapter summary 08

Methodology 09

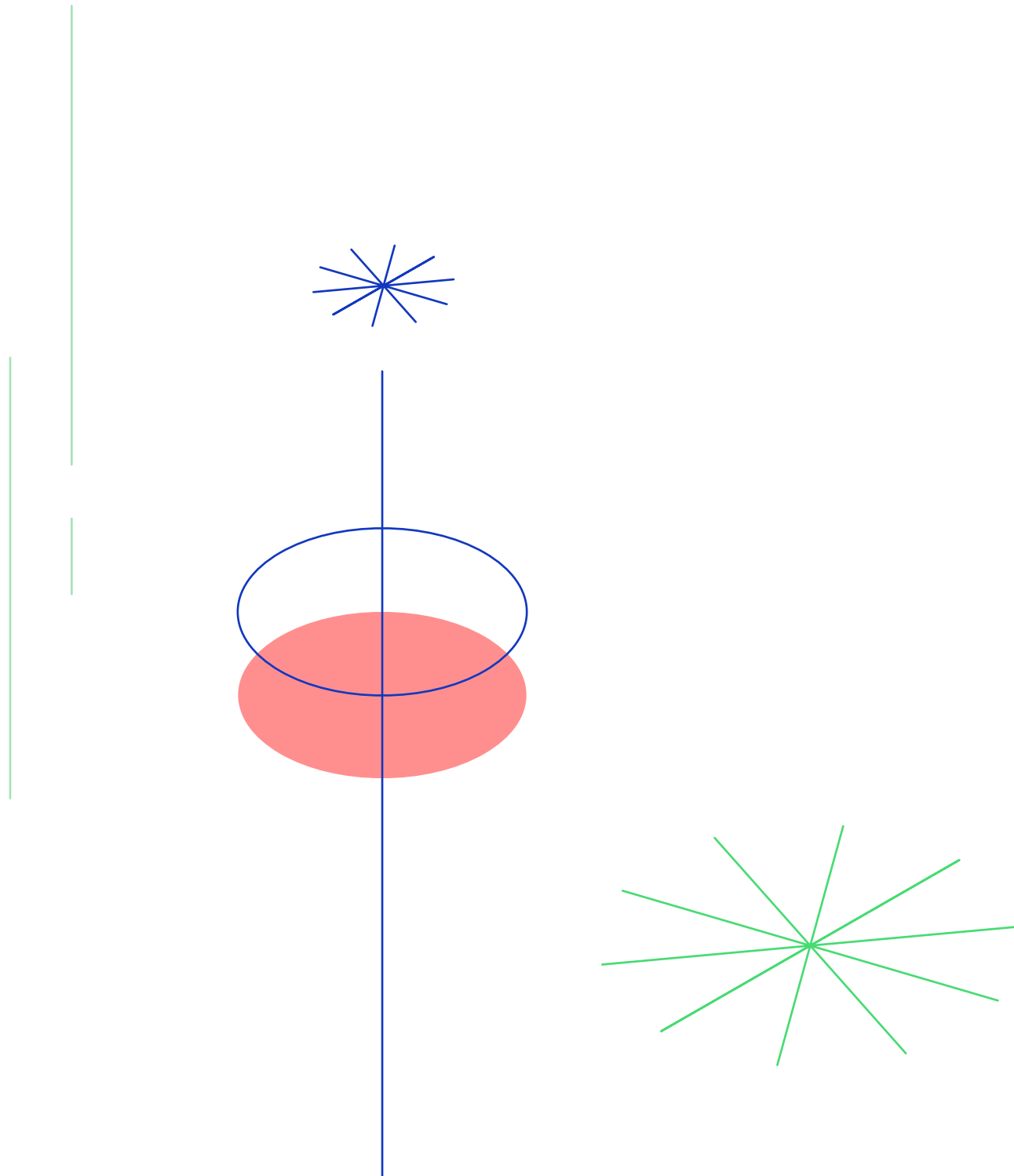

Future of ecommerce

10

Executive summary	11
Trend 1: Rising acquisition costs force brands to foster long-term relationships with their customers	12
Key takeaways	13
Recommendations: How to combat rising acquisition costs in 2022	18
Merchant spotlight: Pai Skincare	23
How Shopify can help	25
Trend 2: Death of third-party cookies forces brands to rethink personalization	26
Key takeaways	27
Recommendations: How to build community in 2022	31
Merchant spotlight: Superplastic	35
How Shopify can help	37
Trend 3: New commercial opportunities emerge on the biggest social platforms	38
Key takeaways	39
Recommendations: How to win at social commerce in 2022	45
Merchant spotlight: Glamnetic	48
How Shopify can help	50

Future of retail

51

Executive summary	52
Trend 1: Digitally native brands drive retail competition	53
Key takeaways	54
Recommendations: How to create experiential moments that win over customers	60
Merchant spotlight: Lively	65
How Shopify can help	67
Trend 2: The post-pandemic customer journey will bring about the next phase of omnichannel shopping	68
Key takeaways	69
Recommendations: How to succeed in the next phase of omnichannel commerce	75
Merchant spotlight: The Sheet Society	78
How Shopify can help	80
Trend 3: Consumer and employee expectations push brands to reimagine the retail staff role	81
Key takeaways	82
Recommendations: How to improve the employee experience and meet customer expectations	87
Merchant spotlight: UNTUCKit	90
How Shopify can help	92

Future of shipping and logistics

93

Executive summary	94
Trend 1: Supply chain vulnerabilities force merchants to permanently modify their fulfillment and shipping strategies	95
Key takeaways	96
Recommendations: How to build a resilient shipping and fulfillment strategy	102
Merchant spotlight: Doe Lashes	107
How Shopify can help	109
Trend 2: Social and environmental impact will define the next era of shipping and logistics	110
Key takeaways	111
Recommendations: How to make your supply chain more sustainable	116
Merchant spotlight: A Good Company	120
How Shopify can help	122
Trend 3: Customers choose to shop with brands that are transparent around delivery times	123
Key takeaways	124
Recommendations: How to overcome shipping challenges in 2022	130
Merchant spotlight: Manly Bands	134
How Shopify can help	136

YOUR ROADMAP TO THE FUTURE OF COMMERCE

Navigate the rapidly changing commerce landscape with the top trends shaping 2022 and beyond, and the recommendations you need to build a brand that lasts.

The only constant in commerce is change

Businesses have dealt with more change in the last two years than in the previous two decades. As a side effect, we've grown more resilient. And it's a good thing—because there's a lot more change ahead. Changes like record-high shipping costs, diminishing returns on online advertising, and a massive increase in the number of channels businesses are selling on.

All this will affect the way we shop, sell, and ship. So we're sharing every insight we have to help your business succeed.

This is more than speculation. Our report is based on in-depth analysis of exclusive survey data from businesses and consumers around the world. We paired this with data from millions of Shopify-powered businesses globally. The result is a trends forecast with unparalleled views into the future of commerce.

We're shining a flashlight into 2022, and we're ready to show you the way.

Spending habits are shifting

We're seeing a radical change in consumer behavior. People are more willing than ever to buy from brands that resonate with them because of geography, company values, or sustainability.

According to a commissioned study conducted by Forrester Consulting on behalf of Shopify, 47% of the consumers said having a local presence was a significant factor for which brands they shop from.¹ Consumers are 4x more likely to purchase from a company with strong brand values.² And a whopping 77% are concerned about the environmental impact of the products they buy.³

They're willing to spend more money and accept slower shipping times—for the right brand. They're also returning to in-person shopping, and shopping in new ways: social commerce sales are set to nearly triple by 2025,⁴ and 40% of consumers say they plan to pay with cryptocurrency in the next year.⁵



Businesses that not only own their customers and know who they are, but are speaking to them and listening to them, will have a definite advantage going forward.

Robert Befumo
Head of Ecommerce
Strategy and Marketing,
Parkfield Commerce

Caution: obstacles ahead

What got you where you are won't get you where you're going.

There's no sense sugarcoating it: Our retail woes aren't over. "Shortage" is a word that will define the coming year. Supply chains, resources, and access to staff will remain constricted for businesses while consumer demand keeps going up.

Know what else is going up? Shipping and acquisition costs. The average cost of a shipping container is now over \$10,000, four times higher than a year ago.⁶

And as third-party cookies phase out and advertising conversion rates continue to plummet, 80% of marketers will likely abandon personalization efforts by 2025.⁷

Hiring and retaining employees will continue to be a top challenge for businesses in North America, and Europe. Retail workers will need to become far more versatile, helping with things like virtual shopping, appointment shopping, click and collect, and local delivery. These obstacles and others are chronicled in our report so you can prepare for the road ahead.

Global container freight costs

\$1,000 U.S. per 40-foot container

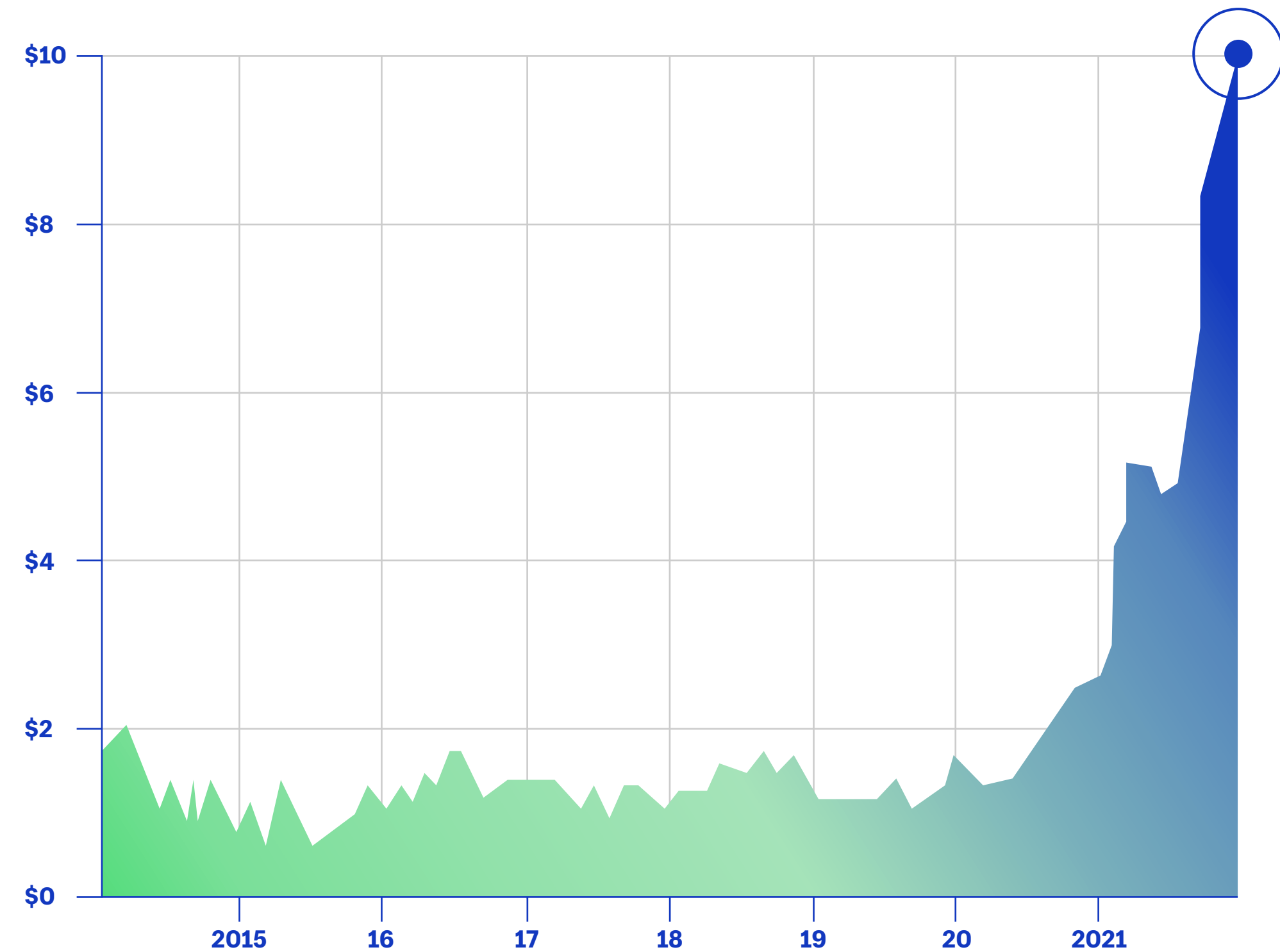

*Based on eight major shipping routes

Sourced from Drewry in The Economist

Look at obstacles as opportunities

Differentiate and diversify: These are your two keys to succeed in 2022. This is the year of competing not on price, but on brand proposition. People want to buy from brands that stand for something, brands that align with their personal beliefs. Fifty-two percent of global shoppers are more likely to purchase from a company with shared values.⁸ Given this, brands should focus on customer retention and lifetime value, especially as advertising costs and uncertainty continue to climb. Prepare to invest more in your customer experience, and build a community that keeps customers coming back.

Don't forget about the magic of in-person experiences: in-store shopping is ramping up again. But it's not about one or the other—consumers want it all. These days, commerce is omnichannel. The best brands understand that digital and physical retail don't operate as silos. It's all just retail. Your customers want to be able to order online but return in store, or look at a product in a showroom and buy it online. Over the next year, 54% of consumers say they're likely to look at a product online and buy in store,⁹ and 53% are likely to look at a product in-store and buy online.¹⁰

Future-proof yourself further by building diverse business relationships across your supply chain, shipping, and fulfillment networks. And give yourself a Plan B, C, and D to build resilience in your supply chains. Most importantly, make sure you can deliver on your promises to your customers. Sixty-six percent of them are already aware of supply chain delays,¹¹ and they're looking for transparency. Forty-five percent of shoppers are actively looking to shop from businesses that clearly show anticipated delivery times.¹²

Perhaps the largest opportunity ahead is to differentiate yourself with sustainable business practices. In the past year, nearly half of customers chose to buy from brands that have a clear commitment to sustainability.¹³ Studies have shown a 71% rise in online searches for “sustainable goods” globally since 2016.¹⁴

It could be said that if you don't go green, you'll go red—so seize the chance to build a sustainable business.

“

As the world has moved online and as commerce has had its second renaissance, the side effect is that customer acquisition costs have risen to enormous levels. The clear solution for brands is to increase their repeat rates and increase customer lifetime value.

Carl Rivera
VP of Shop, Shopify

YOUR ROADMAP

The 2022 Future of Commerce report dives deep into three areas of commerce: ecommerce, retail, and shipping and logistics. Here's a preview of what you'll find.

Future of Ecommerce

As third-party cookies are phased out, get ready to experiment with new ways to deepen direct relationships with customers like live shopping, NFTs, private communities, and VIP events.

[Read now](#)

Future of Retail

More digitally native brands will expand into physical retail than ever before, leading to a new phase of omnichannel shopping. And new consumer expectations will change retail staff into experiential hosts.

[Read now](#)

Future of Shipping and Logistics

Supply chain vulnerabilities are forcing merchants to permanently change their fulfillment strategies, and customers are demanding more transparency and eco-friendly business models. Sustainability will define the next era of shipping.

[Read now](#)

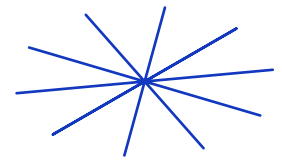

Methodology

Shopify's 2022 Future of Commerce report is based on data from the Shopify platform, which supports millions of Shopify merchants operating in the United States, Canada, Asia Pacific, Europe, and the Middle East.

We paired this data with a global commissioned study conducted by Forrester Consulting on behalf of Shopify. The survey covered consumers and businesses living and operating in Australia, Canada, France, Germany, India, Italy, Japan, the Netherlands, New Zealand, the United Kingdom, and the United States. The study included 12,000 global adult consumers who have made an online purchase in the last year, and 350 commerce strategy and decision makers at consumer packaged goods and retail companies that generate at least \$500,000 in annual online revenue.

Third-party data included in this report has been sourced from Statista, eMarketer, Global Web Index, Google, IBM, Deloitte, Accenture, Gartner, McKinsey, Forrester, Nielsen, and the World Trade Organization. Corporate data and consumer insights have been sourced from the quarterly earnings calls of Walmart, Target, FedEx, UPS, Home Depot, Lowe's, Shopify, Salesforce, Adobe, Microsoft, PayPal, Nvidia, and The Trade Desk.

We also conducted more than two dozen interviews to gather insight from industry leaders, investors, and subject matter experts. Prior to publication, the report was reviewed by third parties with expertise in ecommerce, global trade, and consumer behavior.

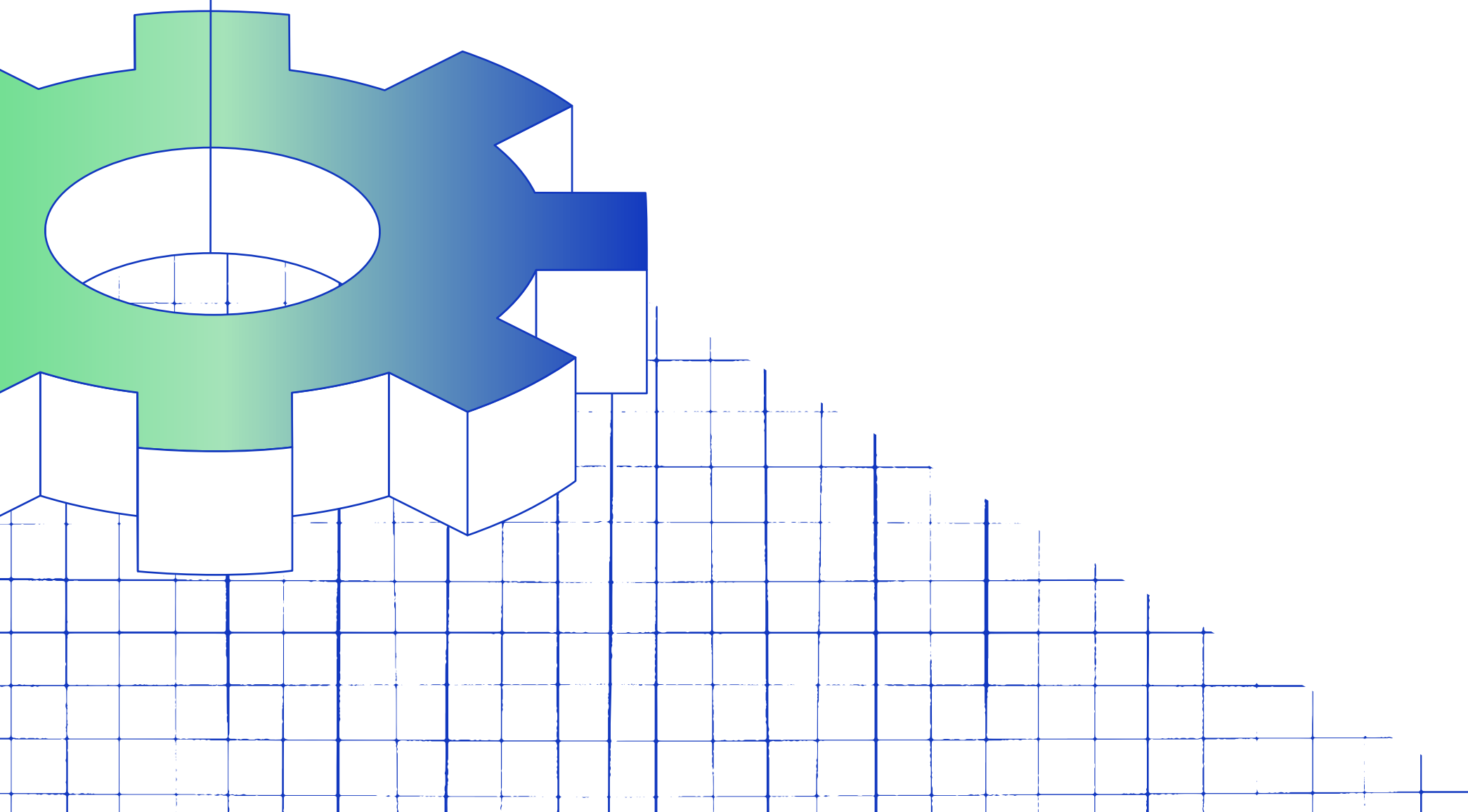

Future of Ecommerce

The ecommerce trends, insights, and advice you need to succeed in 2022



EXECUTIVE SUMMARY

There have never been as many opportunities in the ecommerce space, nor has there been as much competition. Plummeting return on ad spend is pushing brands to prioritize customer lifetime value and promote brand loyalty.

Trust is the main currency of the future of ecommerce. Brands must be transparent, authentic, and readily available to their customers, especially where online consumers spend most of their time: on social media. Social commerce is at the center of online shopping for tomorrow's consumer, with brands investing in video and live shopping.

Direct-to-consumer (DTC) companies are also investing in online communities to humanize their brands, increase customer retention, and overcome skyrocketing advertising costs.

Thriving in this new ecommerce landscape will require unique insight and action. We conducted extensive research with hundreds of DTC brands and thousands of consumers to identify the most important trends for 2022, as well as the strategies and products your business needs to stay ahead of the competition.

Welcome to the future of ecommerce.

TREND 1

Rising acquisition costs force brands to foster long-term relationships with their customers

Businesses strengthen customer connections by putting their brand identity front and center

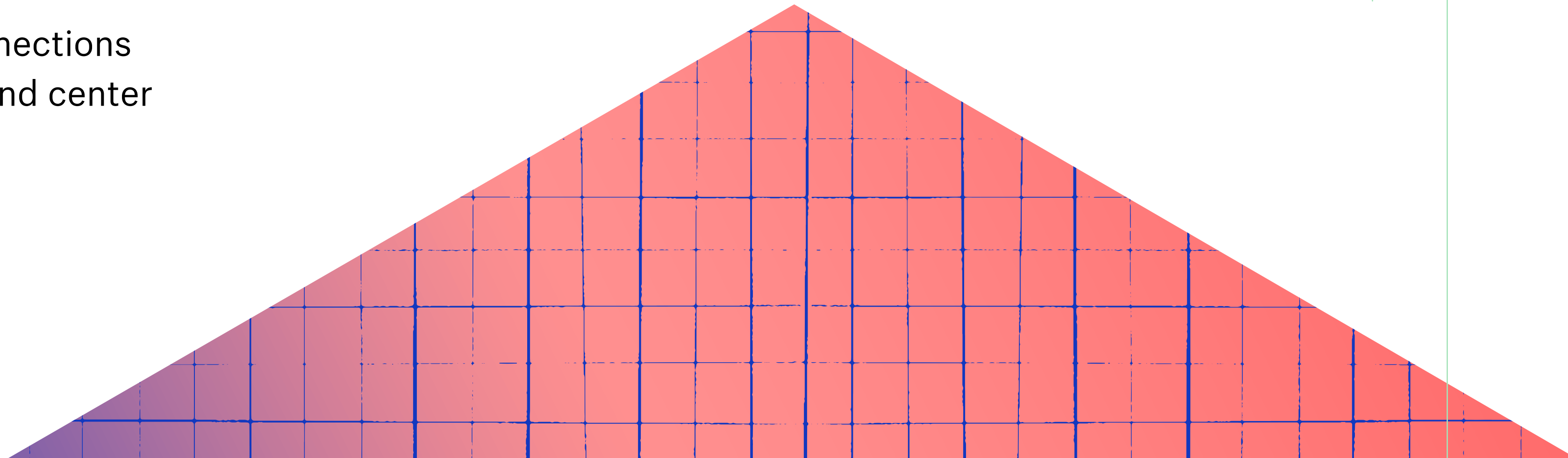

KEY TAKEAWAYS

Direct-to-consumer competition is rising

Although retail business doors have reopened, ecommerce sales aren't slowing, resulting in an influx of DTC brands competing for customer attention.

Advertising costs are skyrocketing across platforms

Digital advertising costs are eating up marketing budgets, putting performance marketing-heavy customer acquisition models in jeopardy.

Brand building is helping attract and retain customers

Businesses are overcoming the competition by investing in brand building, which increases customer lifetime value, boosts conversion rates in the short term, and attracts out-of-market buyers in the long term.

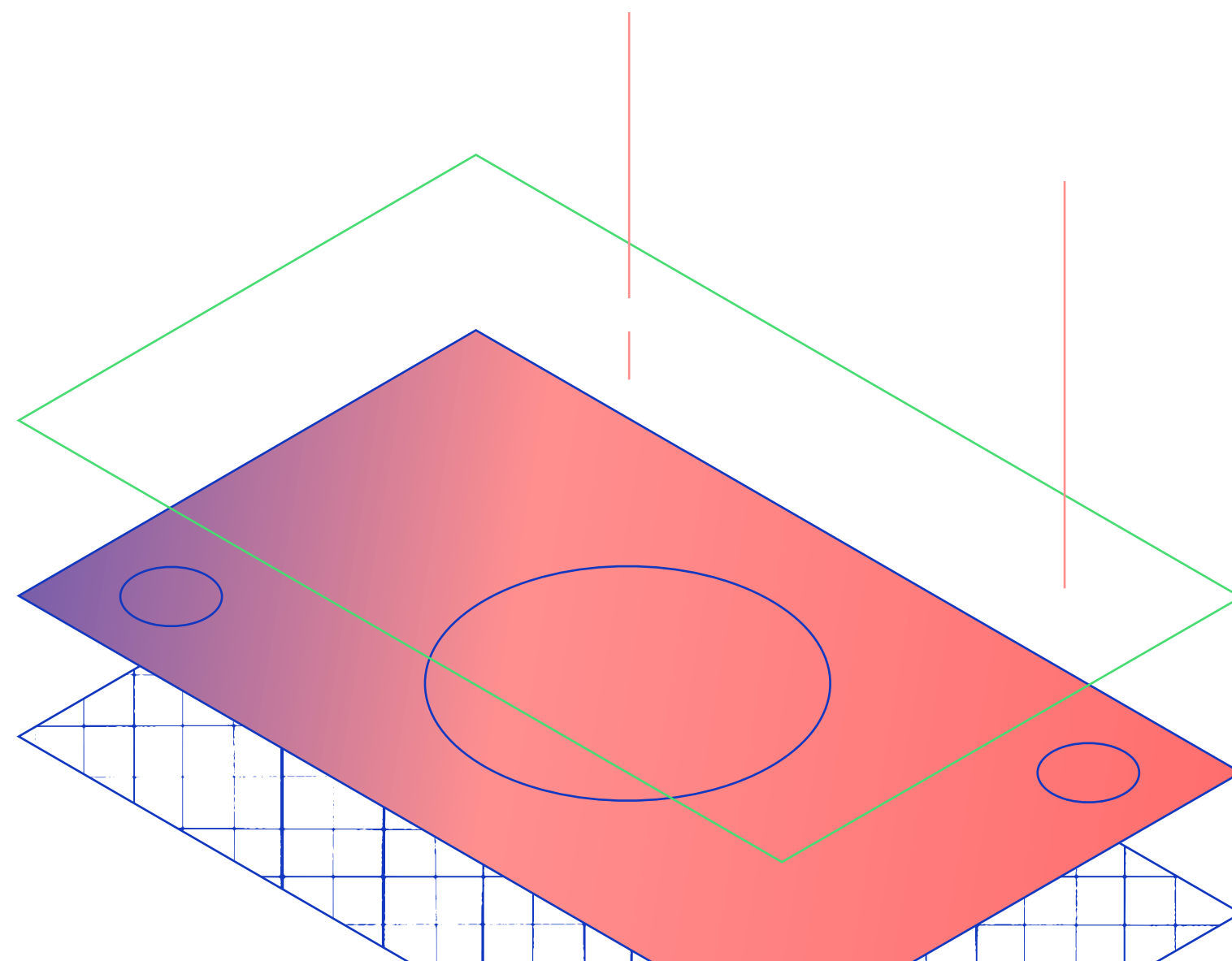

Fewer barriers to entry mean more online retailers

Advancements in technology and the growth of available marketplaces have made it easier than ever to buy and sell online. As businesses came online during the COVID-19 pandemic, the global trend toward digitization surged ahead at lightning speed. Even as regions begin to reopen, ecommerce sales are still climbing.¹⁵

Retail ecommerce sales worldwide from 2014 to 2024

In billion U.S. dollars

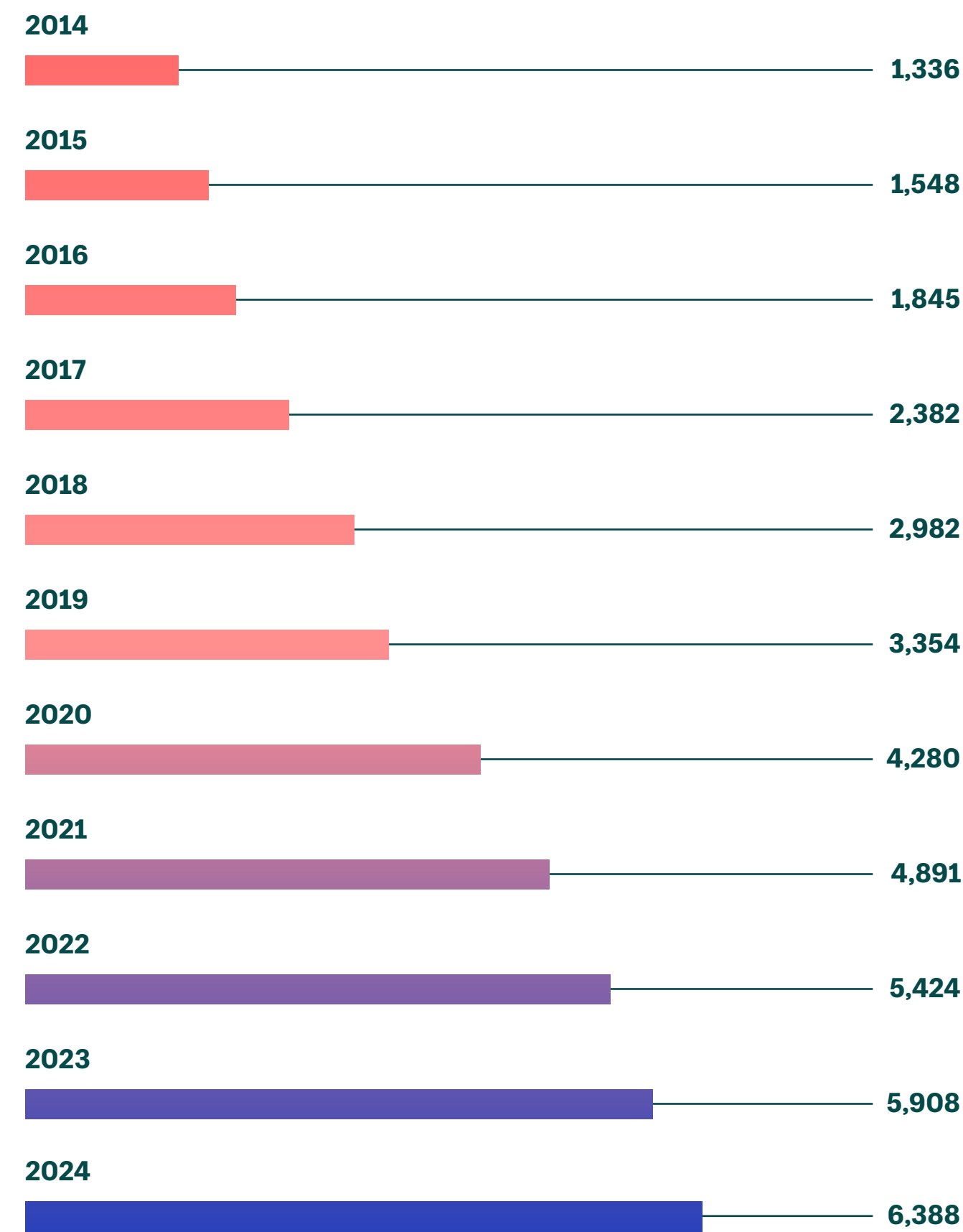

Sourced from [Statista](#)

Merchants continue to follow consumer demand online, flocking to ecommerce in record numbers. This means more brands competing for customers. As a result, digital advertising is more costly and less lucrative than ever before.



As more businesses are online, it's harder and harder to be found by new customers. Because it's so easy to start online now, there are definitely rising costs of customer acquisition. Paid ads are getting really expensive, not to mention the Apple iOS 14 release, which has made it more difficult to track results in ad spend.

Mel Ho
Senior Product Marketing Lead, Shopify

Merchants are spending more and gaining less

Competition is the biggest obstacle to achieving growth in 2022,¹⁶ according to the 350 global commerce decision makers surveyed for this report. With privacy laws that limit marketers' ability to target ads and consumers who are better at blocking ad interruptions, it's becoming tougher to get a decent return on advertising spend. The cost per click for paid search ads increased by 15%¹⁷ between the second and third quarters of 2021 alone.

“Our [July 2021 report](#) showed a 15–20% drop in the advertising reach of Instagram in Europe,” says Kepios founder and CEO Simon Kemp. “That’s huge. Tens of millions of impressions disappeared because of certain kinds of laws and changes in Apple’s policies.”



Some brands are seeing ad costs go five times higher than [before] to drive the same amount of traffic.

Ben Jabbawy
Founder and CEO, Privy

41%

of brands plan to increase investment in their paid and organic search

Shopify eCommerce Market Credibility Study, 2021

Despite the changing digital ad landscape, 41% of brands¹⁸ plan to increase investment in paid and organic search. Many hope that advances in hypersegmentation will make their advertising dollars more effective by targeting consumers who are ready to purchase.

But there are at least three problems with this approach:

- Audience segmentation is not as reliable as merchants think. Harvard Business Review tested the accuracy of the digital profiles data brokers sell, and the results were dismal.¹⁹ The age tier was only correct 23% of the time, and gender was properly identified in well below half of cases.
- As advertising platforms get more competitive, brands that haven't developed familiarity and trust with consumers will become more entrenched in a direct-marketing battle to offer customers the lowest price.
- Even when high upfront ad costs and granular targeting create short-term wins, they aren't long-term profit drivers. Creating a sustainable customer base will require brands to build awareness and confidence with consumers who aren't ready to buy, or who aren't even in the market yet.

The brands most reliant on short-term performance marketing will struggle the most in the increasingly saturated commerce space. It's no wonder the world's top companies have brand building at the heart of their marketing strategies in 2022.

Get ahead of the competition by investing in your brand

Marketers who want immediate, measurable results tend to undervalue brand, which is a longer-term investment. That's why 70% of marketers²⁰ who are cutting their budgets in 2022 will sacrifice investments in brand building, and only 13% will reduce performance marketing spending.²¹ But performance-based advertising is only part of the equation.

While conversion rates are important, most consumers already have a brand in mind by the time they're ready to buy. In fact, Google reports that more than 80% of customers²² conduct their research online before making a purchase decision. A business needs a strong brand to earn their place in the minds of consumers.

A strong brand not only makes performance marketing more effective in the short term, it's also the foundation of sustainable growth. Strong brands draw more organic acquisition, retain more customers, and can raise prices²³—the most powerful lever you can pull to increase profits. As the digital space becomes more crowded, brand identity and brand awareness will only become more crucial.



The brands that speak to everyone speak to no one. Whether brand differentiation means what the brand stands for, the way the product is made, or the way they engage their audience, consumers are looking for differentiated experiences and brands they can connect to.

Morgan Brown
VP Growth Marketing, Shopify

RECOMMENDATIONS

How to combat rising acquisition costs in 2022

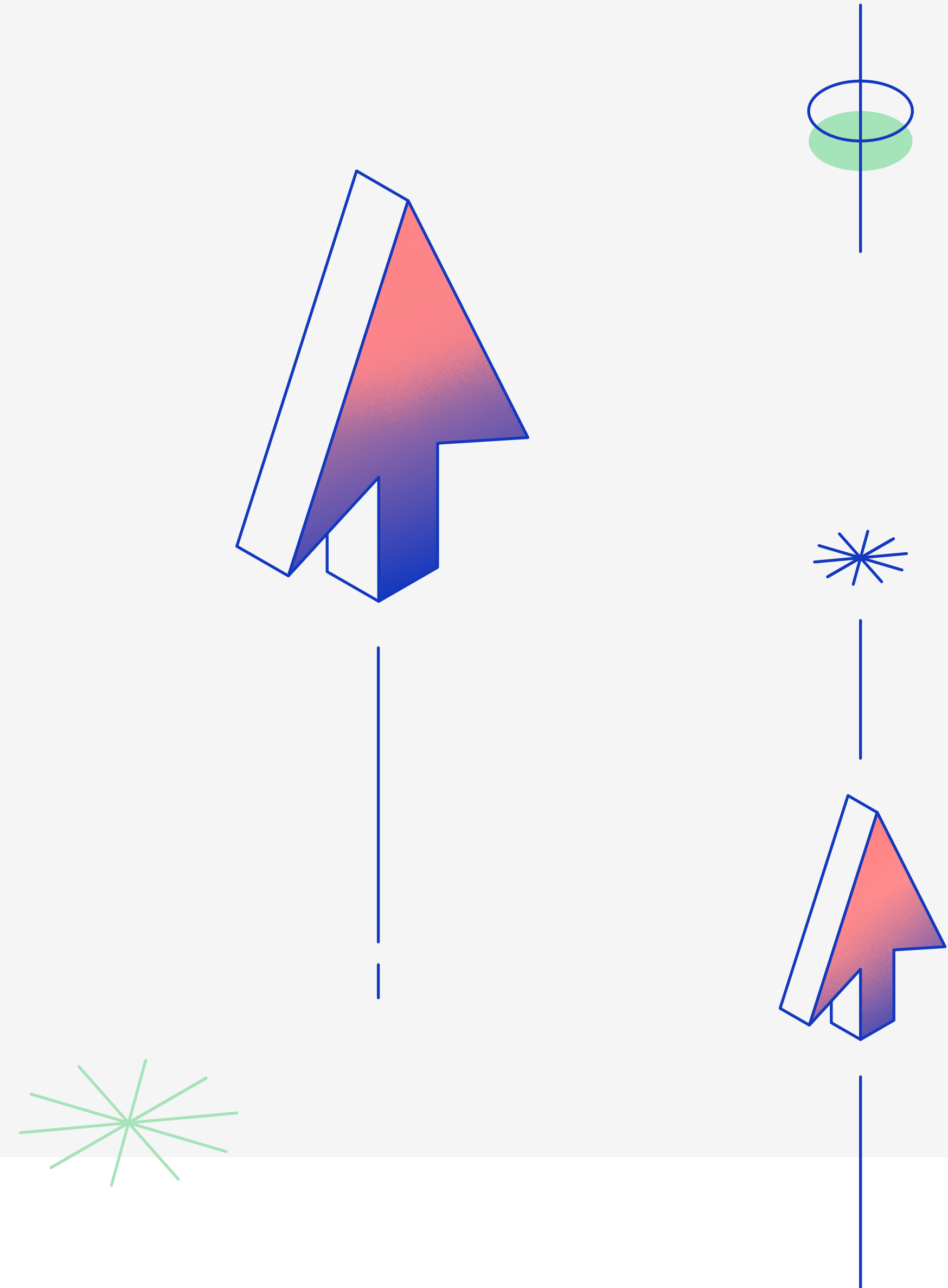

RECOMMENDATION 1

Develop a brand measurement methodology



Align brand activity with your top-level brand goals

With today's attribution modeling and data-driven performance marketing, you can show a clear line to value from your brand-building activities.²⁴ No single metric will be enough to determine the success of brand activities. Instead, build a measurement framework with performance indicators aligned to your top-level brand goals, like growing share of mind, market share, or brand consideration. Expect to run brand campaigns for at least six months²⁵ before seeing a measurable impact.



Gather data through consumer surveys

Consumer surveys are a tried-and-tested method for brand measurement. You can use responses as inputs to metrics like net promoter score, brand awareness, brand perception, purchase intent, brand recall, and category preference.



Monitor your site and social analytics

Record changes before and after a brand campaign by measuring direct traffic, organic traffic for branded keywords, and backlinks. On social platforms, pay attention to an increase in followers, social engagement, and especially shares. Share of voice, measured across pay-per-click advertising, search engine optimization (SEO), social media, and public relations, can also be a strong predictor of market share.²⁶

RECOMMENDATION 2

Invest in both short-term performance marketing and long-term brand building



Investing in your brand doesn't mean forgoing performance marketing. Use both performance marketing and brand marketing to create lifelong customers and brand evangelists. You'll need to experiment with the exact split based on your industry and current level of brand awareness, but we recommend aiming for a 60/40 split between brand building and short-term performance marketing²⁷ to achieve increased return on investment from your performance-based advertising in the long term.

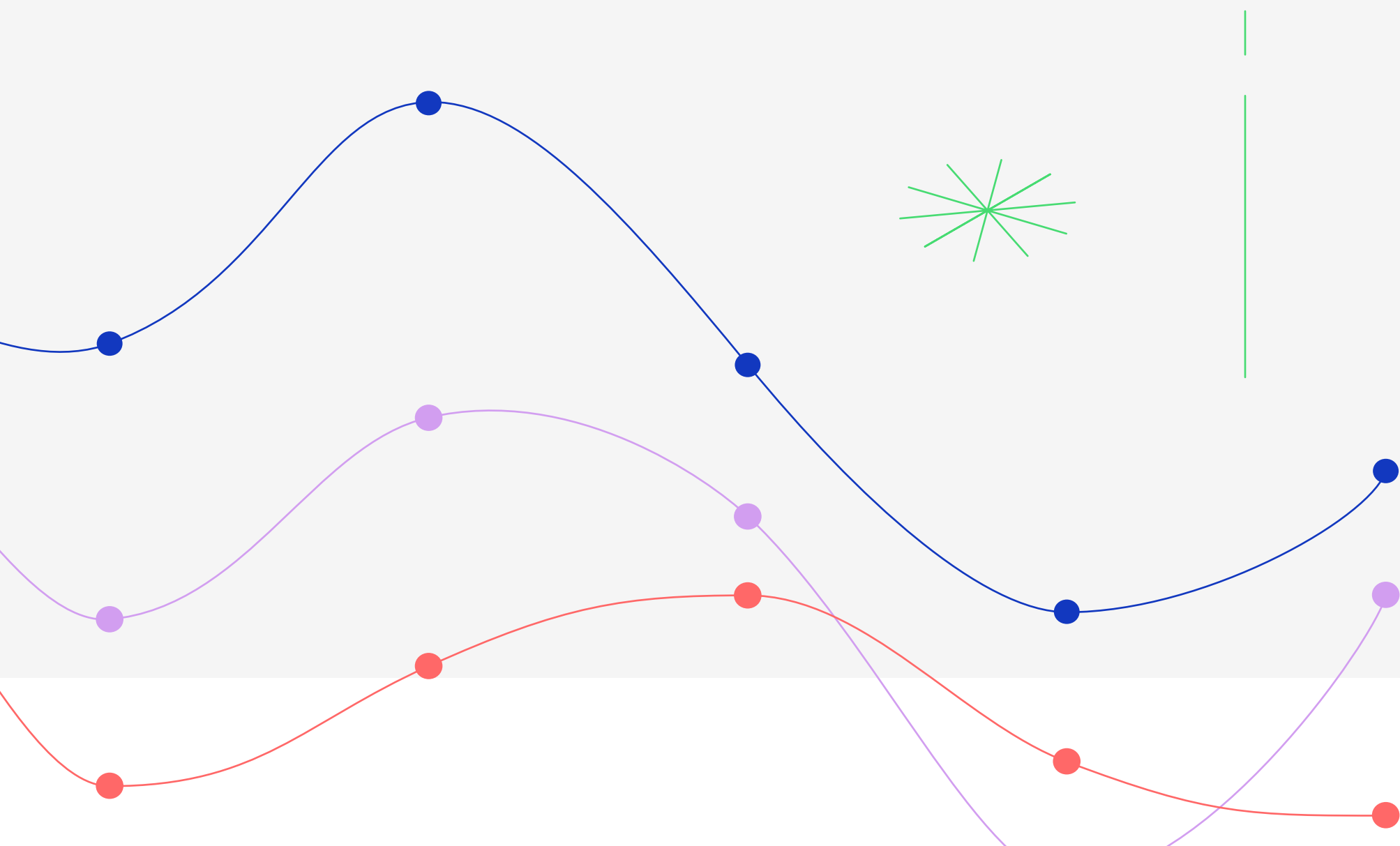

RECOMMENDATION 3

Diversify your advertising and sales channels to lower the cost of acquisition



Explore new channels to reach new audiences

Experimenting with new channels like voice shopping, connected TV, and messaging apps can act as a hedge against digital advertising uncertainty. Global shipments of smart speakers and displays grew 35%²⁸ over the past year, and spending on connected TV ads is expected to grow by double digits²⁹ over the first half of this decade.



Consider investing in niche channels with high engagement

For example, Doe Lashes, a cruelty-free lash brand, shares content on Discord, a popular group chatting platform among gamers that attracts users of the same age bracket as Doe's consumers. And on the apartment design game, Design Home,³⁰ players can purchase physical versions of products in their virtual apartments.



Don't discount tried-and-true channels

Since the start of the pandemic in March 2020 until September 2021, email marketing integrations were among the most popular apps globally, according to internal Shopify data. Email and text continue to be two of the most powerful and cost-effective ways to nurture customer relationships.



Use marketplaces as both sales and marketing channels

Marketplaces are an effective channel for many DTC businesses to get new eyes on their products, yet 44% of brands³¹ report the biggest challenges selling on marketplaces are competing on price and controlling the customer experience. Use a hero product to reach new customers, then incentivize shoppers to move to your site by creating store-only offers.

RECOMMENDATION 4

Highlight your unique differentiators and values at every customer touchpoint

Revisit your brand story and differentiators

Why does your brand exist? What's your origin story? What are your brand values? What needs does your brand meet and for whom? These fundamental questions differentiate you from your competitors, fuel your brand identity, and should form the foundation for any brand-building initiative.

Show your customers you share the same values

Fifty-two percent of shoppers are more likely to purchase from a company with shared values,³² and 53% of brands³³ are creating products in 2022 that align with their values. Be consistent. If you take an ethical stance on social or environmental issues, demonstrate how those values run through your brand, from the top of the business to your customer service representatives.

Patagonia, a brand that actively campaigns for environmental causes, spreads their values through every facet of the company: Its "Worn Wear" program encourages consumers to buy and sell used items, and its "Drive-Less" program rewards employees for reducing emissions on their commute to work.

Treat your employees as a target audience for your brand

As your company grows, it's easy for your brand's purpose to get lost further downstream. But your employees (including in-store retail staff and customer service teams) are a key part of how consumers experience your brand at every touchpoint. Thinking about your employees as a brand audience, and running marketing programs to help educate them on your brand purpose, experience, and messaging, will improve the consistency and quality of how your employees communicate your brand value to customers.

MERCHANT SPOTLIGHT

How Pai Skincare leads with its values on owned channels

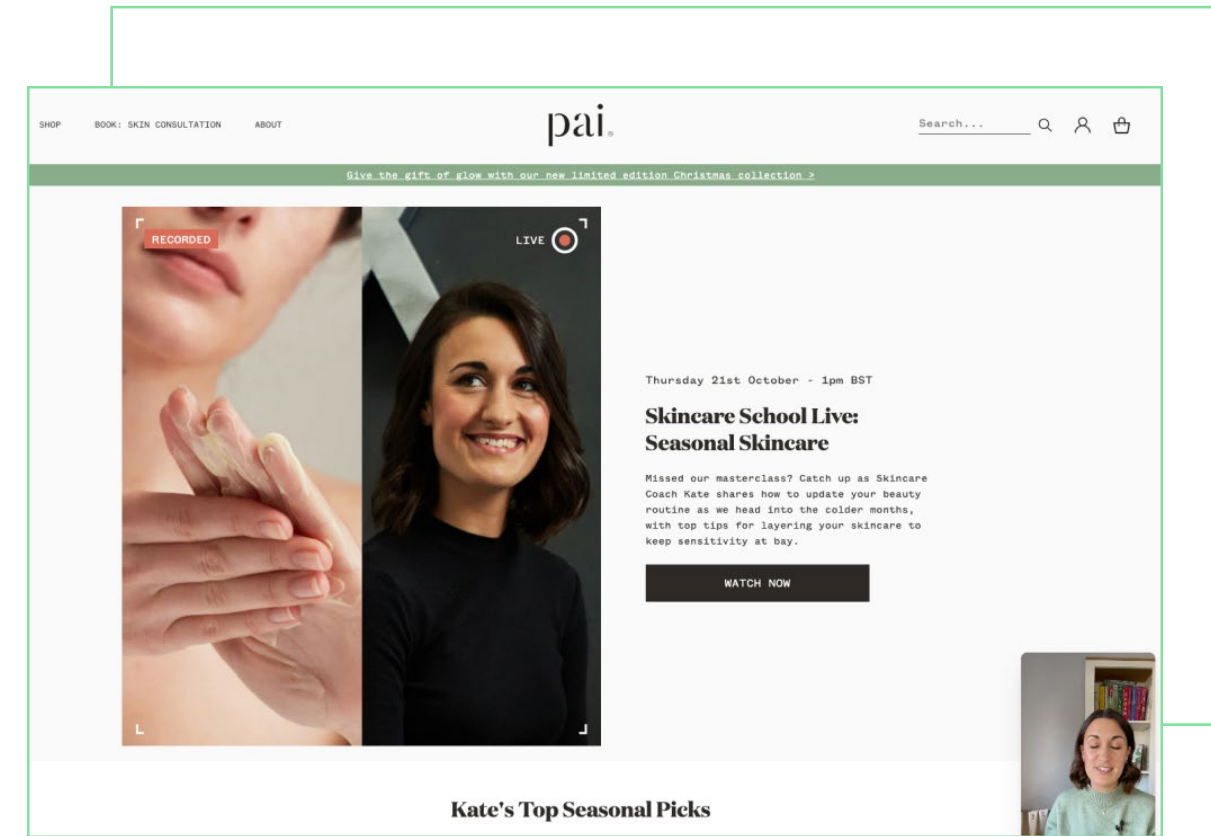

Pai Skincare, a United Kingdom-based brand selling sustainable skincare, is investing in brand awareness by leading with its values. As stores in the United Kingdom began to open up, they saw massive fluctuations in online traffic and revenue.

“We have experienced 51% cost-per-click increases in the United Kingdom year over year on our brand,” says Roz Brabner, head of ecommerce at Pai Skincare. “This in itself is forcing us to look outside of performance [marketing] and into more [organic] ways to increase traffic.”

Digital marketing costs skyrocketed in 2021, so the brand is looking to make large investments into a long-term acquisition strategy through brand building.



Customers are looking for brands to align with their values. They are calling out complacency and demanding transparency. A purchase now represents your values, a demonstration of shared beliefs between customer and brand.

Sarah Brown
Founder, Pai Skincare



MERCHANT SPOTLIGHT

The brand undertook a site rebrand to bring its values to the forefront, highlighting clean, organic ingredients (accredited by Cruelty Free International, The Vegan Society, and the COSMOS Natural Certification) on product pages, as well as a commitment to sustainability.

Every component of product development and packaging was recently reviewed to improve the company’s carbon footprint or recyclability. Pai Skincare’s recycling scheme makes it as frictionless as possible for consumers to dispose of parts of the product packaging through household recycling and to send the rest back with a prepaid shipping label for the company to specially recycle.

Beyond the website, the brand is evangelizing its values across email, social media, its skincare coaches, and on live shopping streams.

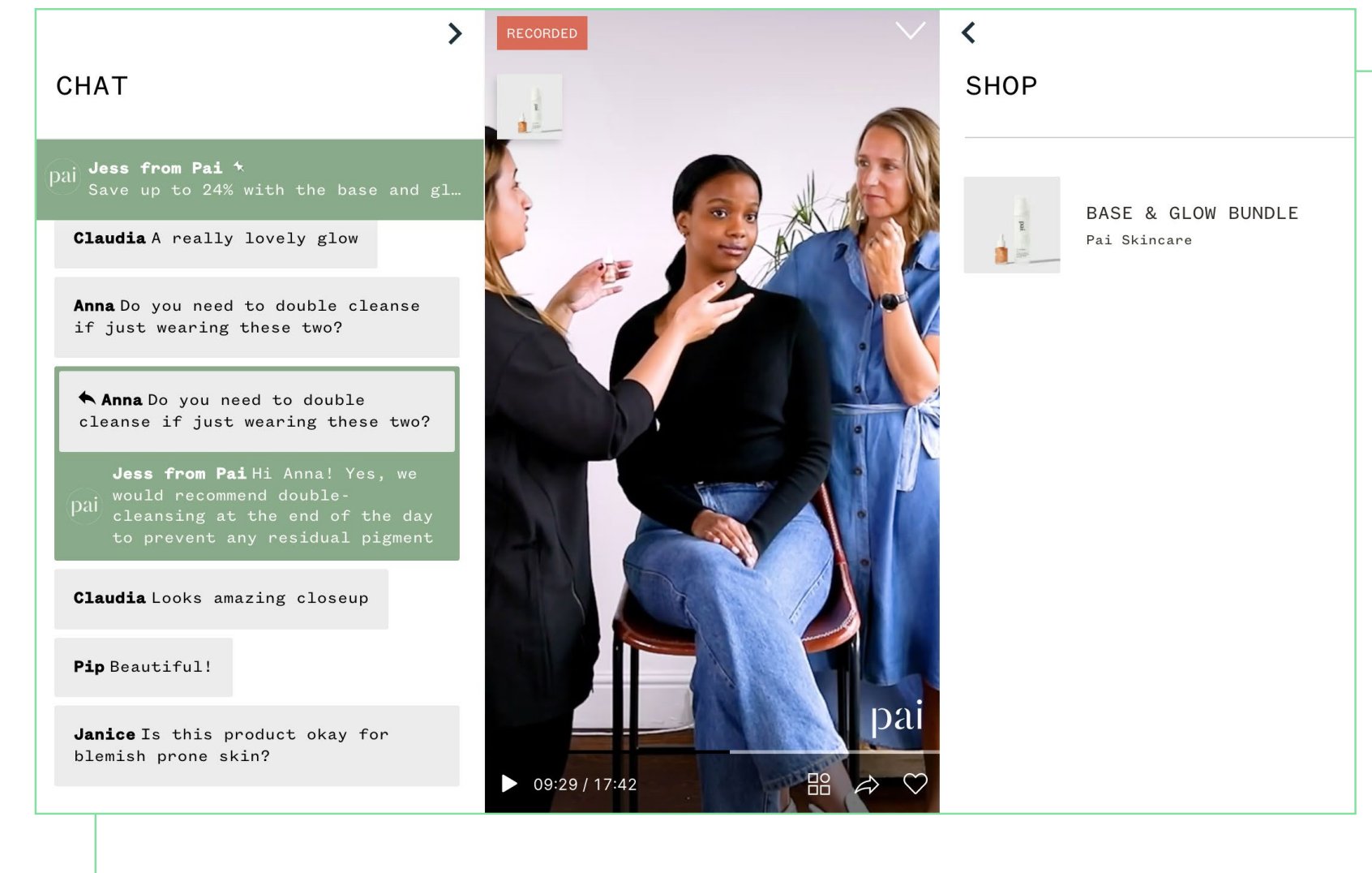

“We have a brand founder that’s great in front of the camera. Sarah, who is a really confident host, knows every single ingredient in every single product. We get a lot of compliments about the kind of content we put out.”

Roz Brabner
Head of ecommerce, Pai Skincare

How Shopify can help

Create consistent customer experiences

How you tell your story and what you stand for, while creating a consistent end-to-end customer experience, will be a critical differentiator in 2022. Consistency is key to unlocking repeat business and customer lifetime value, but requires the technology and infrastructure to embed your brand wherever your audience happens to be, at every touchpoint in their journey.

- Build a standout brand experience that highlights your unique differentiators and values with the Online Store sales channel—equipped with easy-to-use templates and drag-and-drop technology that requires little to no code to bring your brand to life
- Deliver a consistent online and offline shopping experience by bringing your products to life online with interactivity and digital immersion from augmented reality (AR), virtual reality, and 3D media

Use custom storefronts to build cutting-edge experiences

Build one-of-a-kind shopping experiences anywhere—from video games to smart mirrors—with custom storefronts, Shopify's solution to going headless. A headless architecture separates your front-end storefronts from your back-end tech stack, giving you more control over your buyer and developer experience.

Many Shopify merchants are already using custom storefronts to build unique commerce experiences:

- Allbirds' mobile app lets customers try shoes on virtually with AR
- Off-Limits created a vending-machine-like buying experience that led shoppers to a gamified checkout to make buying cereal fun
- Yolélé created a one-of-a-kind visual product explorer for its products
- Zsa created a user-friendly customization process allowing every shopper to personalize their ergonomic Moonlander keyboard

[Explore custom storefronts](#) →

TREND 2

Death of third-party cookies forces brands to rethink personalization

Online retailers rehumanize their brands through communities, transparency, and shared values

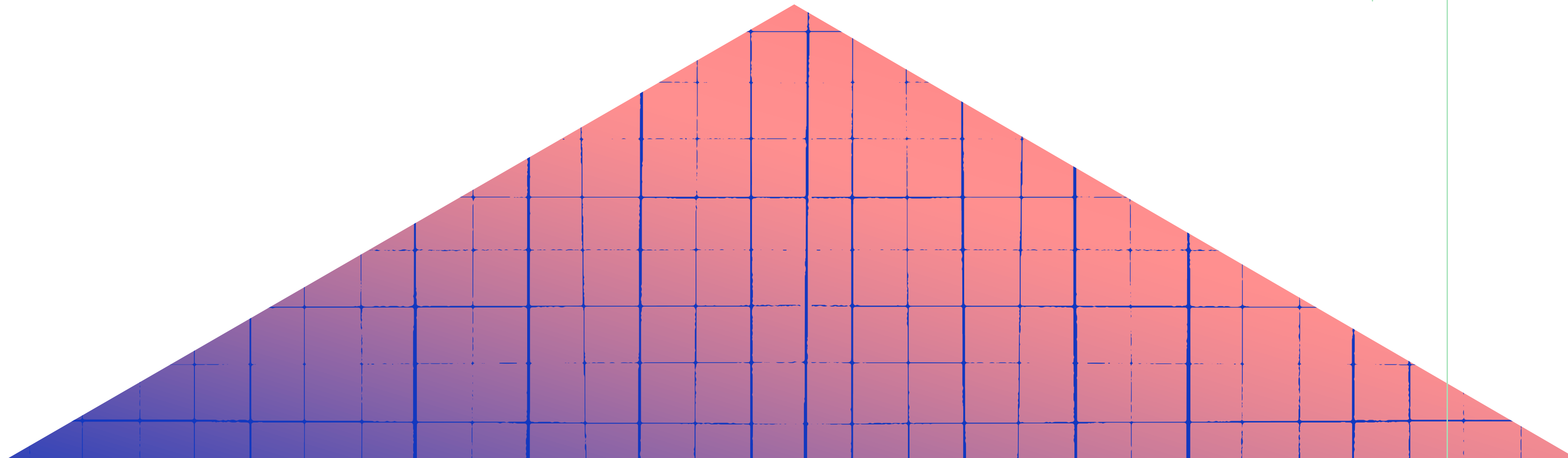

KEY TAKEAWAYS

Consumers are demanding personalization

Consumers continue to demand personalized shopping experiences, even as regulations make data tracking harder, and the biggest players phase out support for third-party cookies.

Personalization isn't a magic bullet for customer engagement

Brands innovate with first-party data, but personalization isn't enough to create long-term relationships with customers.

Brand communities are building customer loyalty

Brand communities become key to building trust and brand equity, and improving customer retention.

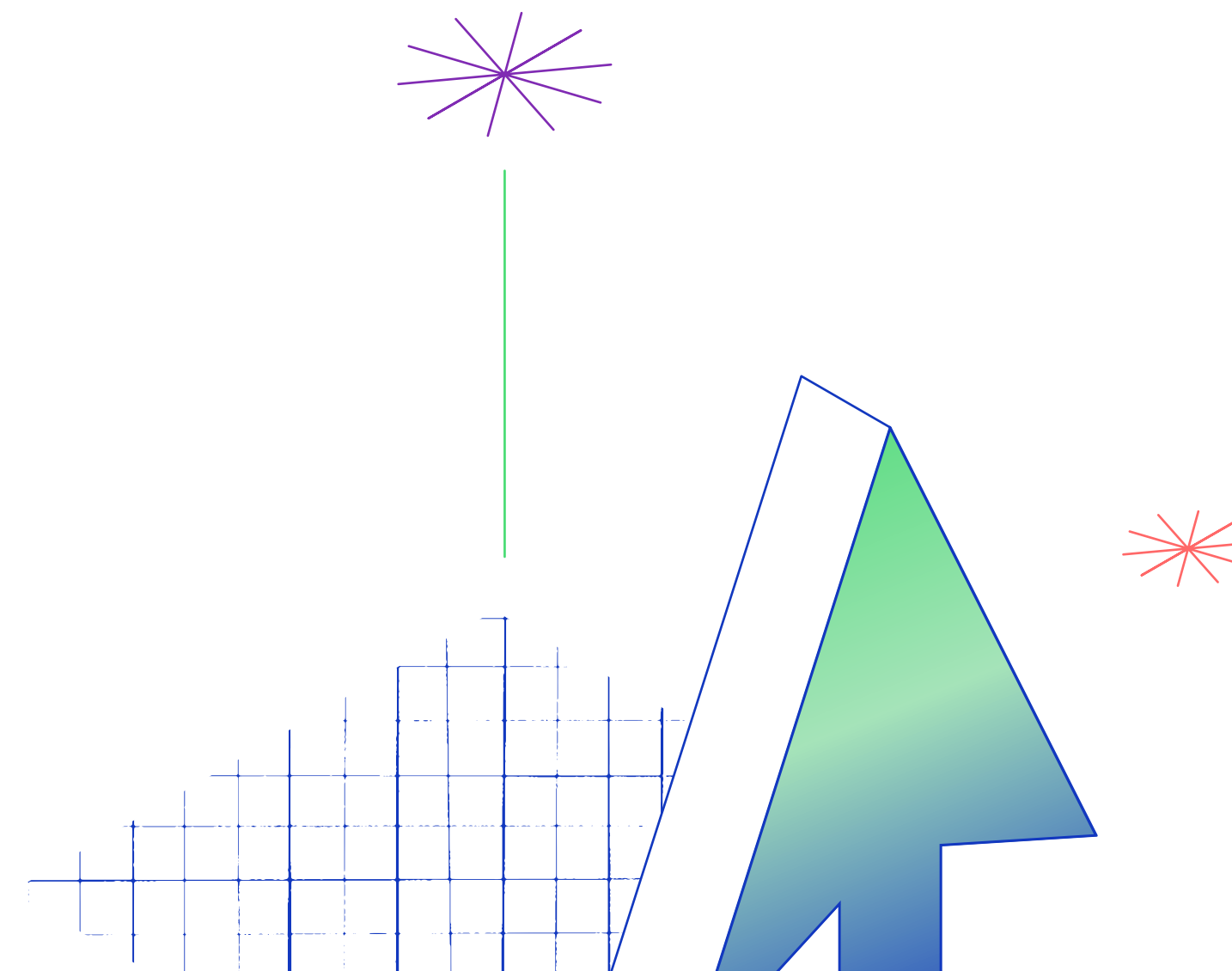

Consumer behavior and privacy laws complicate personalization efforts

Internet users are exercising their privacy rights, and governments are making it easier for them to do so. In November 2021, China's Personal Information Protection Law³⁴ came into effect. And only a few months before, Brazil began issuing penalties to violators of the country's General Data Protection Law³⁵. California's Consumer Privacy Act put data transparency into state law immediately before the pandemic,³⁶ and The European Union's General Data Protection Regulation (GDPR) has cost some businesses dearly in fines³⁷ since its institution in 2018.

Compliance costs aren't the only problem these laws pose to businesses. At least 28% of technology decision makers³⁸ around the world expect changes to customer data and privacy regulations to hinder their 2022 growth goals.

Apple, Firefox, and Brave already automatically block third-party cookies. Google Chrome, representing over 60% of search engine market share, announced in July 2021 that it will delay third-party cookie blocking until late 2023.³⁹ But that doesn't mean brands should rely on Google's cookies in 2022. In a commerce world where [omnichannel](#) is king, the fragmented customer experience offered by the third-party cookie isn't cutting it anymore. More importantly, customers are more privacy aware than ever before and trust is getting harder to earn.

Brands are turning to first-party data to fill the void third-party cookies will leave. This is the data a brand collects directly from their customer, with their customer's consent. In 2022, 42% of brands⁴⁰ plan to offer their customers personalized product recommendations through tools like quizzes, custom mobile apps, and first-party or third-party behavioral data. And to encourage data sharing, 44% of brands⁴¹ already plan to be more transparent around how they use customer information.

Personalization isn't making brands more personable

Consumers want to know how brands use their data

I will only share my personal information with a brand if required



I'm increasingly concerned with how brands use my personal information



I am OK with brands I like using my personal information to deliver relevant content and offers



I have refused to buy from a brand because of concerns around personal data use



Sourced from Shopify eCommerce Market Credibility Study, 2021

Although personalization is now standard fare for online shopping, what personalization means to consumers and marketers doesn't always match.

Consumers are over three times more likely⁴² to abandon brands that “over-personalize,” compared to brands that fail to personalize enough. Including too much personal data in customized communication can make consumers feel stalked by brands.

But there's a nuance here: Forty-four percent of consumers say they're OK with brands they *like* using their personal information to deliver relevant content and offers.⁴³

Consumers are willing to share personal information with businesses that align with their identity. If businesses want access to customer data, they need to do it in a way that builds trust.

85% of brands believe they're offering personalized experiences, while only 60% of consumers seem to agree

[The State of Personalization in 2021, Twilio Segment](#)

Generate customer loyalty and data through community

When access to customer data is so dependent on trust, it's no wonder that brands will invest more in customer loyalty and connection⁴⁴ than almost any other customer acquisition and retention strategy over the next year.

As brands look to strengthen relationships with customers, many have turned to community building. Brand communities have been rising in prominence over the last several years, and for good reason: Communities increase customer retention and brand awareness, and decrease customer support costs.⁴⁵

Community and customer retention will be what many DTC brands lean on to thrive in 2022.

So what is community? The three markers of community⁴⁶ are a shared identity, rituals and traditions, and a sense of responsibility to serve one another.

Cultivating a community of brand fans isn't restricted to any one medium. It can happen on traditional social channels or proprietary channels. It can extend to [chat rooms](#), the [blockchain](#), and in-real-life experiences. The key is to choose (or create) a medium where not just your brand can connect with customers, but fellow supporters can form deep and lasting connections with one another.

"Some brands have yet to even explore digital marketing or paid advertising because their community is so strong. They spend so much time [building] it that it drives the direct-to-consumer revenue."

Kimberly Smith
 Founder, Marjani and Board of Directors,
 National Retail Federation

Percentage of brands creating more ways for customers to interact with them in 2022

(E.g., recipe sites, community hubs)

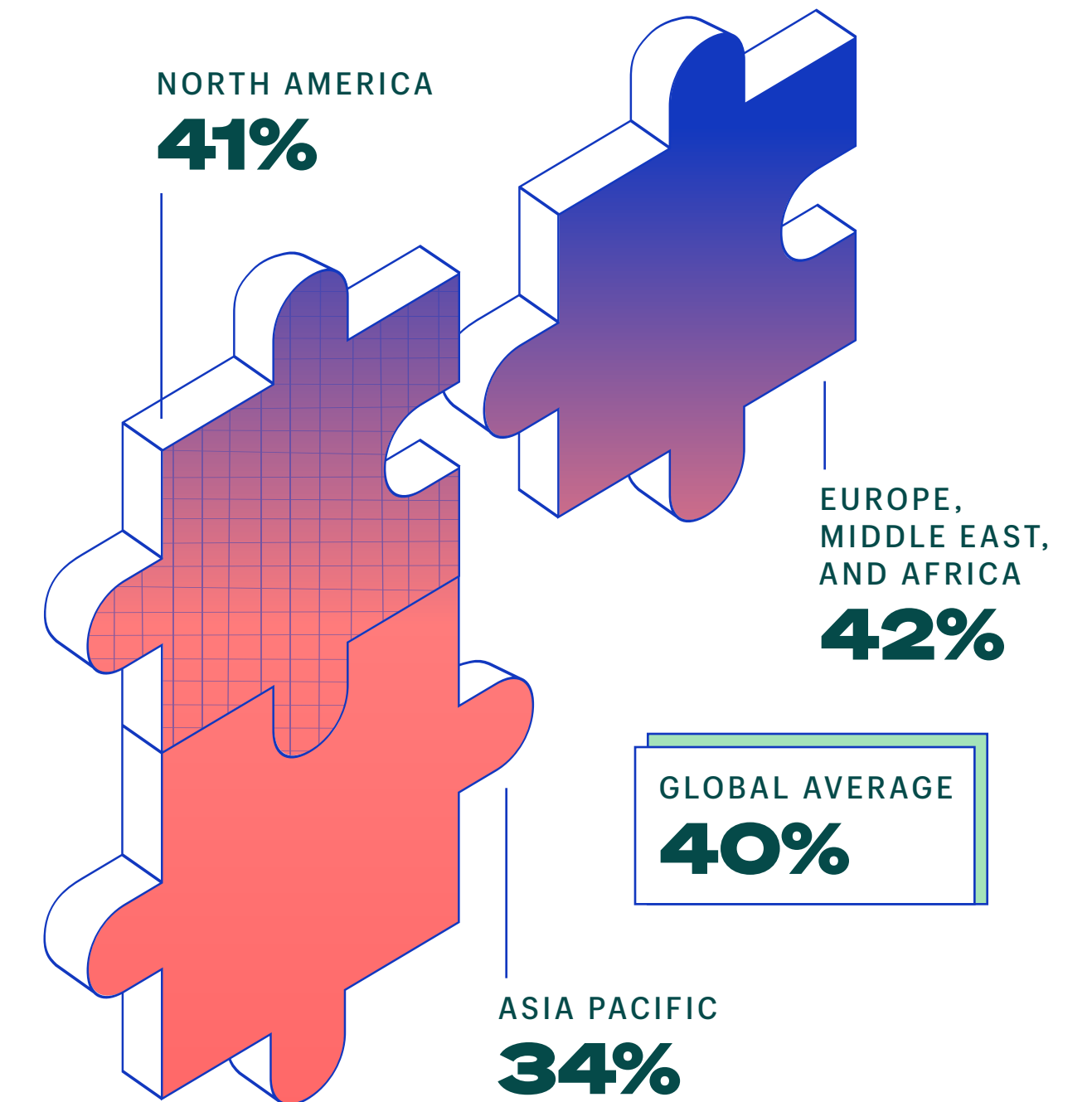

Sourced from Shopify eCommerce Market Credibility Study, 2021

RECOMMENDATIONS

How to build community in 2022

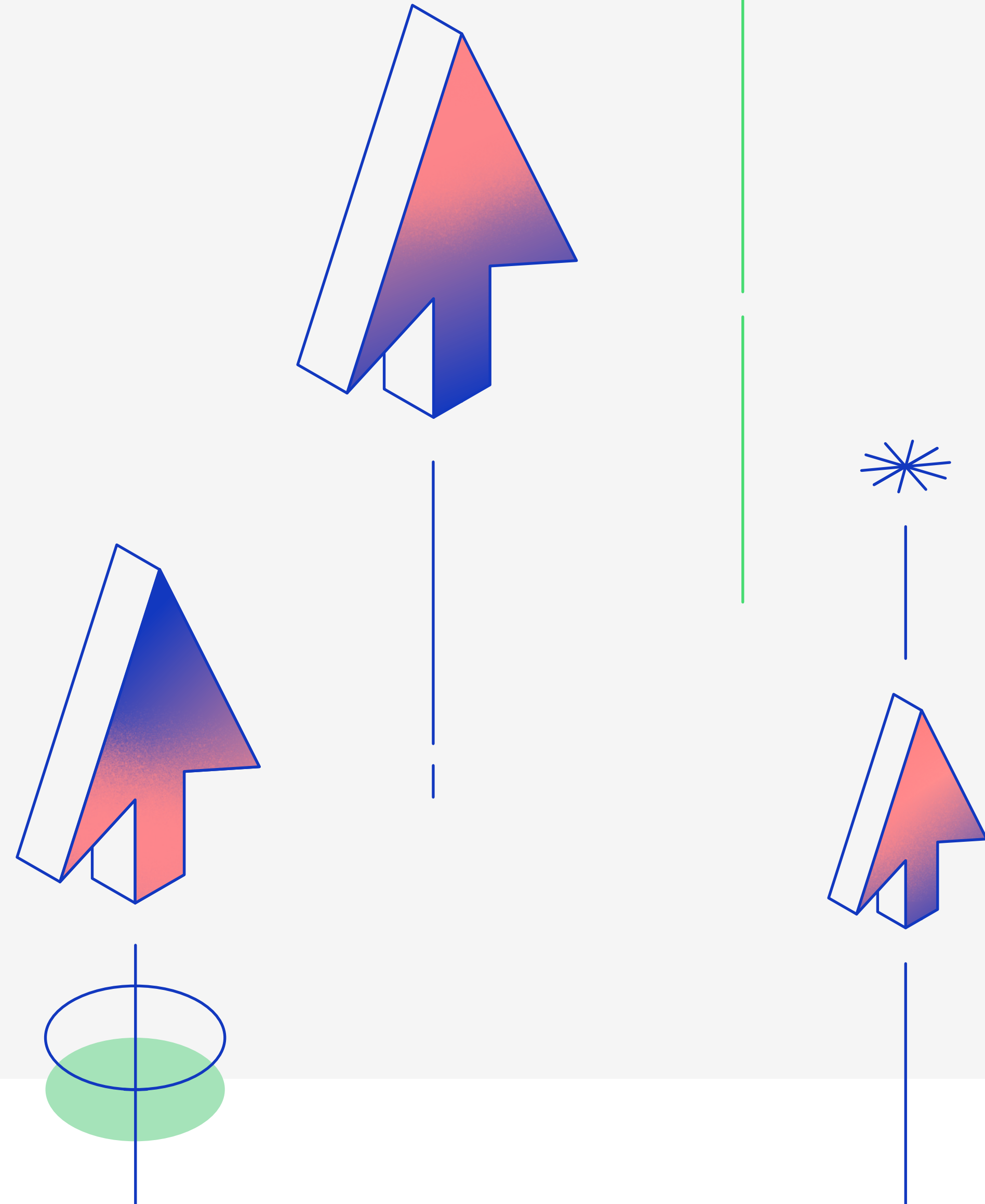

RECOMMENDATION 1

Invest in the right team to help your community grow



Strong brand communities don't emerge by accident, but are a significant commitment of time and resources. As the face and voice of your brand community, community managers:

- Learn about and build relationships with your customers, making it easier to retain and increase community fans.
- Plan and implement social media and communication campaigns that support your overall marketing strategy.
- Serve as the liaison among customers, industry professionals, journalists, and other company departments like development and sales.
- Establish community rules, filter hateful language, and put resources in place to protect members from toxic or abusive conversations. It's crucial to maintain the tone of the community so it reflects the heart of your brand.

RECOMMENDATION 2

Find ways to tie your community back to business results



Set your success parameters

Use data to measure the effectiveness of your community. Aside from seeing success in member growth and retention, your brand community can support your brand's overall marketing and sales goals. Determine which metrics will validate your goals, whether it's lead generation, conversion, decreased costs to customer support, average order value, or customer lifetime value.



Gather and mobilize first-party data

Consumers feel comfortable sharing personal data, as long as they trust who they're giving it to. Feed the results of your community data back into your community strategy and your customer relationship management system to create personalized touches at scale.

Brand communities are also low-risk hubs for testing and iterating new products, and great sources of customer data and real-time feedback.

Doe Lashes uses feedback from its Discord community members to inform product innovations and new designs—and they're not alone. Forty-seven percent of brands⁴⁷ plan to use customer feedback to improve products or customer experience within the next year.

RECOMMENDATION 3

Give members a clear reason to keep coming back

✓ Define your community purpose upfront

With all the work it takes to maintain a healthy community, you need to be clear on why the group exists and how it will give back to both your members and your brand. Are you helping others get answers to questions on your product? How will your community support your business goals? For example, how will a brand community help marketing, support, or sales?

✓ Be intentional about your community's rituals and traditions

A sense of belonging is created through shared values, traditions, and norms. For example, Legos Ideas is a community centered on collaboration. Community members show off their Lego creations and share images of new product ideas. These fan designers also become brand advocates because the only concepts that make it to expert review must have over 10,000 supporters.

✓ Create a feeling of exclusivity by gating your community

While an open community can get you in front of a wider audience, creating "members-only" content or spaces can be a strong incentive for fans to avoid missing out. Your "gate" can be a simple email sign-up, a purchase or series of purchases, a certain number of referrals, posting a review, a donation to a shared cause, or a non-fungible token (NFT).

✓ Offer fans a way to own a piece of your brand

Globally, NFT sales grew 8.5 times⁴⁸ between the second and third quarters of 2021 alone, bringing the worldwide total to nearly \$11 billion. The non-fungible aspect of NFT means that each token is one of a kind, coupling the allure of exclusivity with scarcity. Customers can also show off their brand association as a badge of honor on social channels. Consider offering tiered digital or physical membership benefits with your brand, and leveraging the blockchain and NFT space as proof of authenticity or to track the provenance of physical products.

"NFTs tie the physical good with the digital experience in a unique way that mimics some of the popular limited-release physical good drops we've seen rise in popularity. Translating that into a scarce asset is really valuable to the communities and their passionate fans."

Nicholas Brown
Co-founder and Managing Partner,
Imaginary

MERCHANT SPOTLIGHT

How Superplastic creates an exclusive personalized experience with its loyal fan base

Superplastic, revered for its collaborations with artists and celebs on collectible art toys that sell out instantly, is creating an even more engaged community with the latest technology: NFTs.

Superplastic's animated celebs, Guggimon and Janky, have been featured as Gucci models and Fortnite skins, and will appear in a pop band and motion picture this year. The characters move seamlessly from the digital space to the real world, appearing as collectible toys. Soon their digital selves will also unlock new real-life experiences for superfans.

"We're building a store in New York City, and at certain times, you're not going to be able to get in unless you've got one of our NFTs or tokens in your wallet. It's the same thing with our website. There will be exclusive entry, things only you are able to buy," says Budnitz. "Because if you're willing to make a commitment and join in with us, then we'll make a commitment back to you."



“

NFTs aren't just products—they're somewhere between a product, a game, and code. If you're not using all those things, you're really not using this medium to its full advantage. It's all about the interactivity.

Paul Budnitz
President, Founder, and CEO, Superplastic

MERCHANT SPOTLIGHT

Instead of simply owning a piece of digital art, NFTs for Superplastic have become a promise of community and belonging. NFTs will also get fans into Superplastic's latest sushi restaurant, planned for Miami.

"The blockchain is the world's biggest open-source mailing list. If you buy one of our NFTs, we probably know who you are. We can reach you and send you free stuff. All this is a great way to play games with [your consumer]," says Budnitz.

“

Our job is to sell you the NFTs, and then continually upgrade the artwork, so it seems more and more fun, connected with the other stuff we're doing.

Paul Budnitz
President, Founder, and CEO, Superplastic

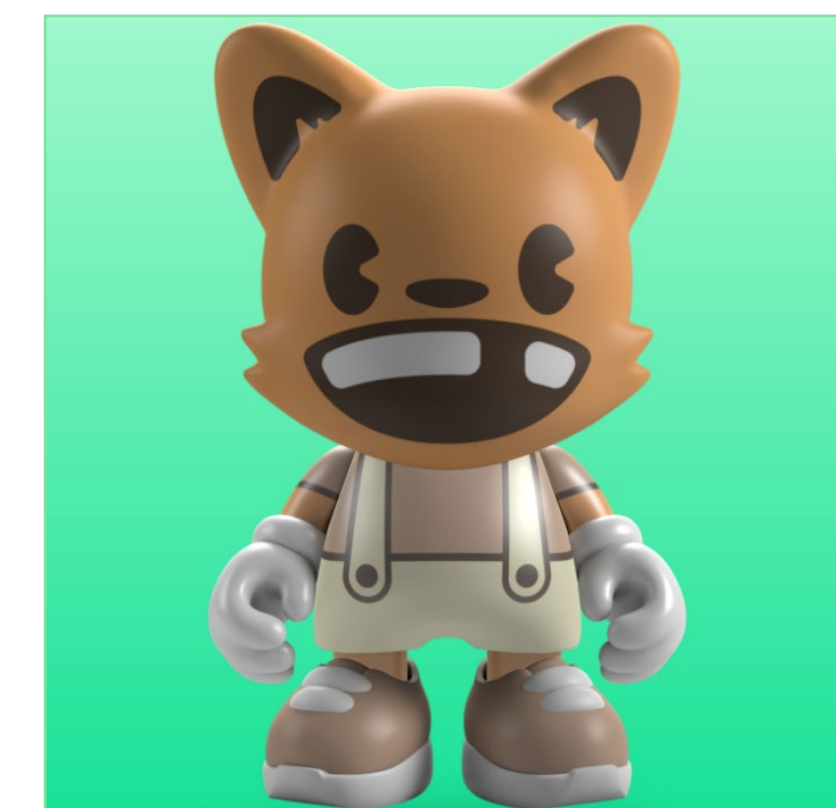
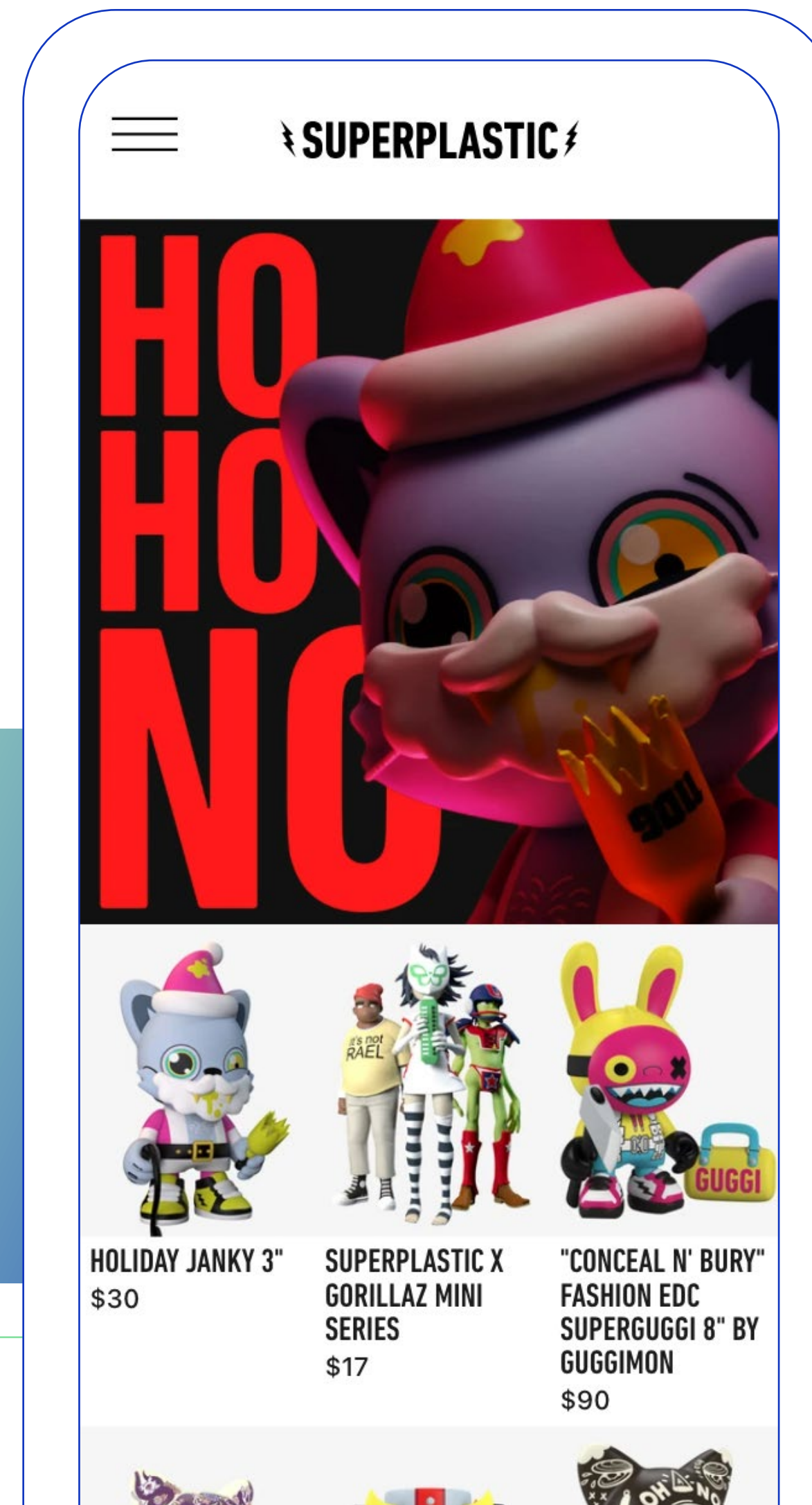

How Shopify can help

Sell everywhere your customers are

With Shopify, you can build a community around your brand by using multiple distribution channels to create a natural feedback loop with consumers about your products, services, or story. Shopify's connected platform helps you manage and analyze those channels, all in one place. Seventy-three percent of shoppers surveyed use multiple channels before making a purchase.

Make every touchpoint your next point of sale with our omnichannel guide →

Add NFTs to your Shopify store

Non-fungible tokens are an exciting opportunity for businesses to reward loyal fans, and create demand around their brand. Shopify has made it easy for eligible Shopify Plus merchants to sell NFTs online.

Right now, both Ethereum and Flow are available to vetted merchants as part of the NFT beta. In the future, merchants will be able to choose which blockchain they want to sell on, based on their products and customer base.

Join the NFT beta →

TREND 3

New commercial opportunities emerge on the biggest social platforms

Brands embrace experimentation to take advantage of social commerce

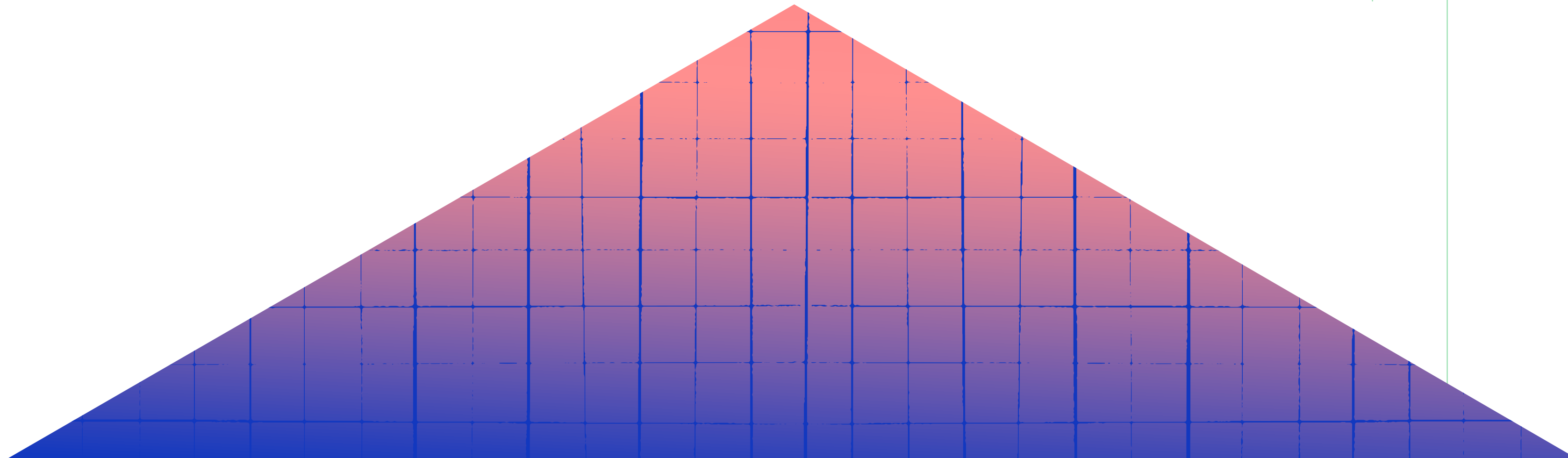

KEY TAKEAWAYS

Ecommerce is migrating to social media platforms

Ecommerce activity is congregating on social media platforms, from brand marketing to customer service to shoppable advertising.

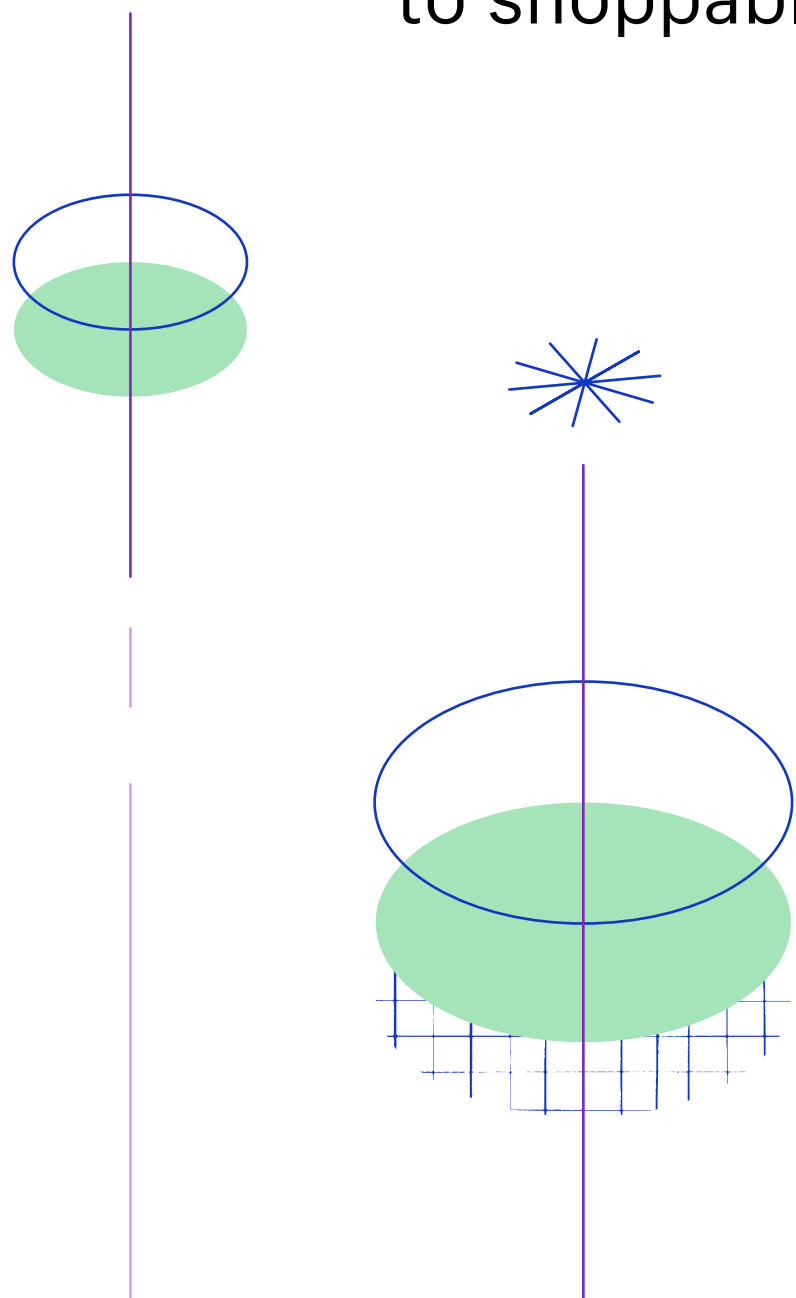

Social platforms are presenting new ways to engage customers

Diverse platforms and rapidly evolving features lend themselves to unique customer experiences, encouraging brands to reimagine consumer engagement.

Video is making social commerce more sociable

Video is key to unlocking the power of social commerce. Leading brands are focusing on social-first approaches like behind-the-scenes livestreams, video consultations, and personalized product recommendations.

Social commerce is on the rise

Sales through social media channels around the world are expected to nearly triple by 2025.⁴⁹ Although about 30% of internet users⁵⁰ in the United States already make purchases directly within social platforms, China is the clear global leader. Almost half of China's internet users shop on social networks, generating more than 10 times⁵¹ the sales of the United States.

Note: Includes products or services ordered on social networks like Facebook, Instagram, Pinterest, WeChat, Line, and VK, and excludes travel, events, tips, subscriptions, bill payments, money transfers, food and drink services, gambling, and other regulated industries.

Retail social commerce sales in China versus the United States, 2021

In billion U.S. dollars

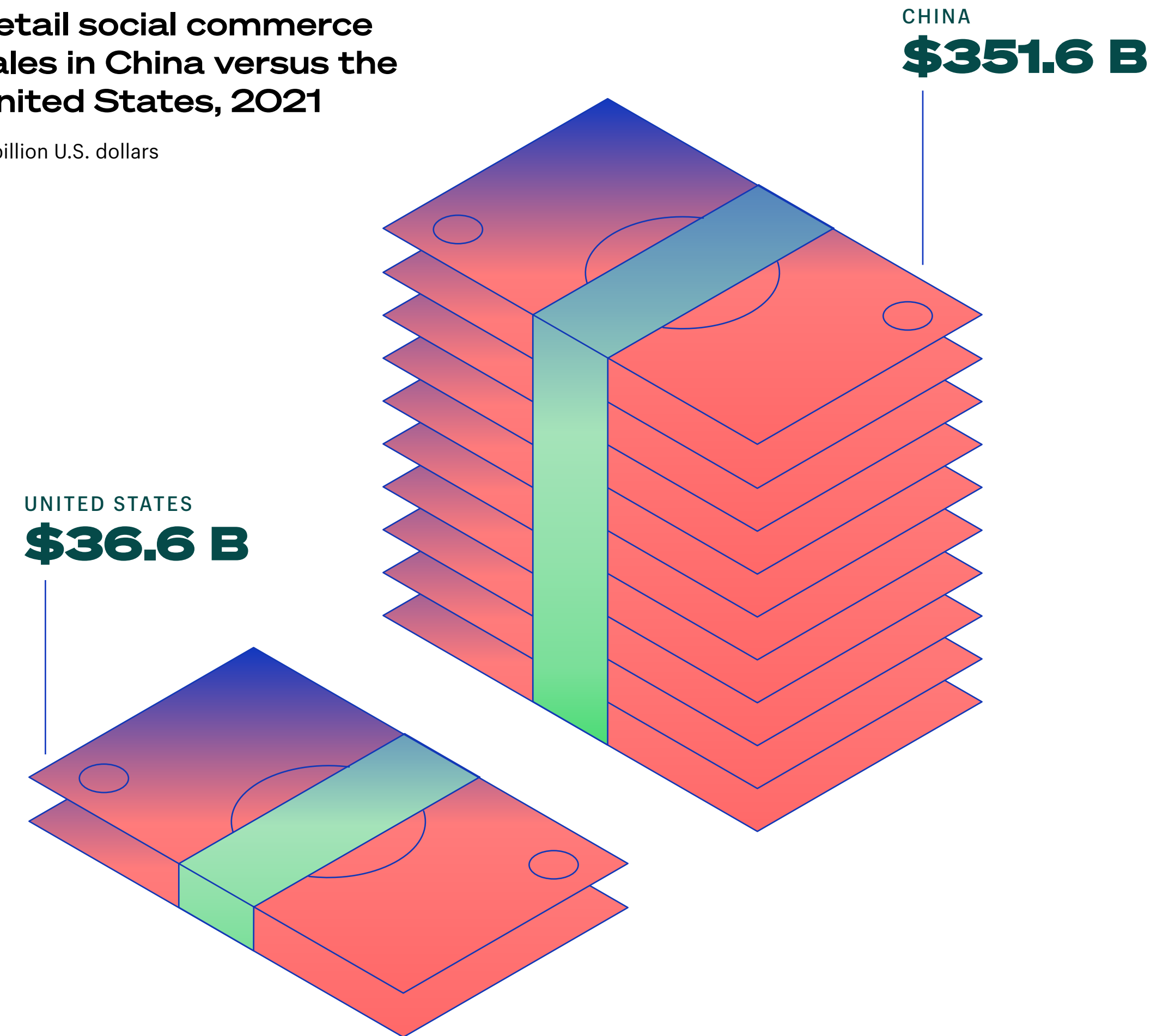

Sourced from [eMarketer](#)

In Southeast Asia, social media is the number one channel for discovery. One in five dollars⁵² spent on online retail in Southeast Asia now happens through social media.

After more than a year of working from home, people around the globe are spending even more time scrolling through social feeds. The typical social media user now spends about 15% of their waking life⁵³ using social platforms.

Social commerce will only get bigger, with more than one-third⁵⁴ of Facebook users planning to make a purchase directly through the platform in 2022. And video has become a clear powerhouse, illustrated by Instagram's pivot to video reels. Instagram product head Adam Mosseri grabbed headlines when he declared Instagram is no longer a photo sharing app,⁵⁵ and would be competing against rapidly growing video sharing platforms like YouTube and TikTok.

The emergence of social commerce is also an opportunity for businesses to take back control of their brands in digital channels. This is especially important as marketplaces continue to dominate around the globe. A total of 38% of consumers⁵⁶ purchase products through marketplaces at least once a month. But the product-centered nature of marketplaces make it easy for brand identity to be overlooked. Through social commerce, businesses can build the brand equity and engagement lacking in most online marketplaces.



Brands build loyalty, not products. It's key for brands to develop their own DTC strategy and model to be able to build a strong, independent brand. Social commerce is definitely an opportunity for brands to reclaim their destiny by owning the customer experience and the relationship with customers, versus selling on Amazon, where price is king and your brand is an afterthought.

Étienne Mélineau
Senior Director of Marketing,
Heyday by Hootsuite

Businesses scramble to update their approach as live shopping explodes

The competition is already heating up: 49% of brands⁵⁷ plan to increase their investment in social commerce in 2022. But businesses that try to take China's social commerce blueprint and translate it directly to other regions will struggle. China's borders house the most digital buyers in the world,⁵⁸ and those online purchases make up over 50% of all retail sales.⁵⁹ The pre-existing fusion between shopping and entertainment in China helped livestream shopping—the rising star of social commerce—emerge almost effortlessly.

Live commerce, which uses social media platforms to fuse livestreaming and commerce, is more fragmented in North America and Europe. This makes it difficult for merchants new to the format to know where to begin. Some companies have partnered with mainstream social media platforms (Walmart and TikTok, Sephora and Facebook), while others have created their own channels outside the well-established platforms. For example, Nordstrom launched its own shopping channel, and Best Buy plans to use its fulfillment center to have associates do livestreams around their products.

61%

Growth in livestream selling app installs globally between January 1, 2021 and September 30, 2021, compared to the same time period in 2020

Internal Shopify data

As consumers buy more on social media, platforms will become more shoppable—as well as more crowded and more transactional. Global ad spend on social media in the third quarter of 2021 was 26% more⁶⁰ than the same period in 2020. But if brands view social media as merely another channel to run ad campaigns, they will hit the same ad-spend walls and fail to build trust with their audiences.

To break through the noise, brands will need to bring the social elements of offline shopping to online spaces.

Live chat and video make social commerce more sociable

Two tactics that will help brands put the “social” back into social commerce are live chat and video.

Live chat

Fifty-eight percent of shoppers say an excellent past customer service experience is a driving factor to influence their purchase decision, and 54% of shoppers⁶¹ say the ability to easily reach customer service in the channel of their choice is important to them.

Live chat is an important channel for 2022, with 43% of consumers⁶² surveyed for this report saying they’re likely to use live chat in the next year. Consumers will also expect to interact with brands in the same way they chat with their friends: through social apps.

Percentage of consumers who say the ability to easily reach customer service in the channel of their choice influenced their decision to purchase

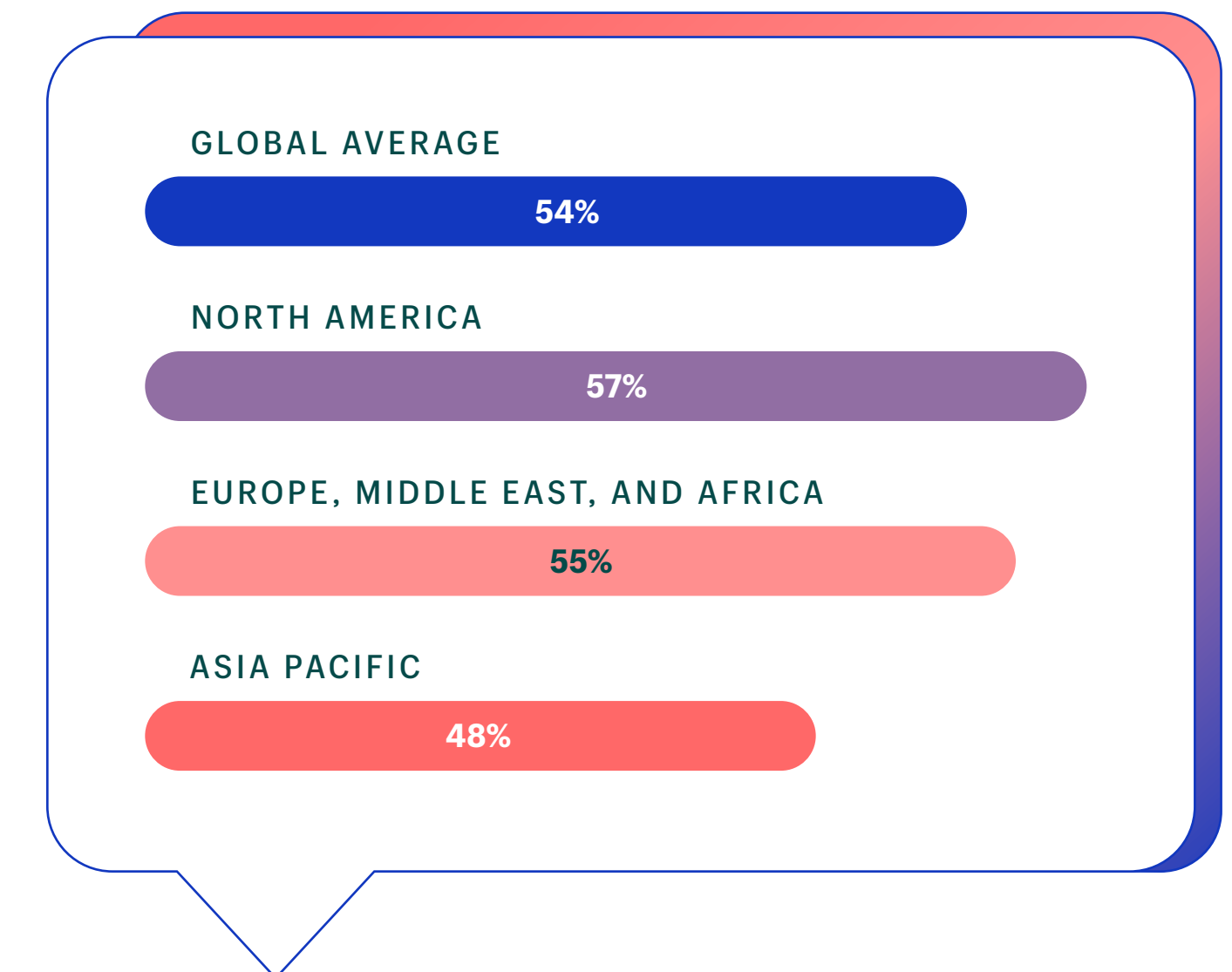

Sourced from Shopify eCommerce Market Credibility Study, 2021



Video

Video is now the default expression of the internet. From web searches to livestreams, video is becoming the primary way the next generation of shoppers make buying decisions. In fact, 46% of consumers⁶³ want to watch product videos before they buy. Eighty-one percent of companies⁶⁴ plan to either increase or maintain investment in livestream selling to drive sales over the next 12 months. And some brands are seeing conversion rates of up to 30%⁶⁵ through livestream selling, along with lower product return rates.



My prediction is that in a couple years, the hottest role for a brand to hire is going to be a head of live shopping.

Kevin Gould
Co-founder, Glamnetic

RECOMMENDATIONS

How to win at social commerce in 2022

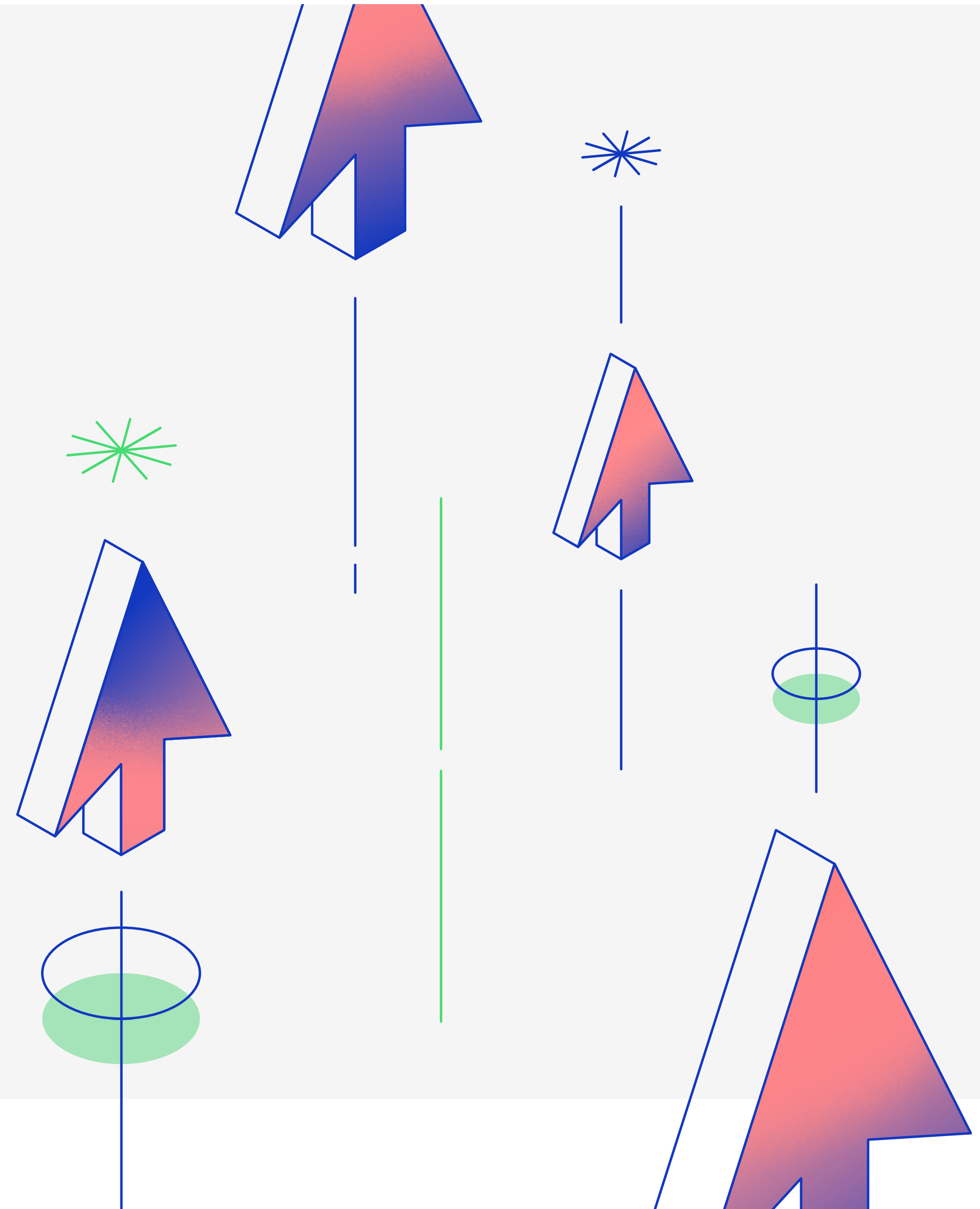

RECOMMENDATION 1

Create live commerce experiences tailored to your audience

✓ Find the right format

- Take advantage of special events like Black Friday, Halloween, and Singles' Day, and host themed live events that allow customers to shop in real time.
- Livestream your product launches with QVC-style product demonstrations⁶⁶ or influencer-led product recommendations.
- Go behind the scenes with your consumers, giving them a peek into how you make your products, how they're sourced, or how they're styled.
- Consider time of day, how long you'll be live for, and which channel will best reach your audience. Whatever the format, have team members on hand to answer questions, moderate the discussion, and guide the conversation.

✓ Choose the right platform

Choose a livestream platform that lets customers purchase without leaving the social channel they're already on. Fewer clicks means less friction and a greater likelihood to convert. Experiment with strong calls to action like "click to buy," rather than "learn more."

✓ Make your live content visually appealing

If you're creating a virtual shopping experience, dress your set with as much care as you would your storefront. Consider using visual prompts and animation, like NYX has mastered for its [virtual cosmetics shops](#).

Visually appealing doesn't always mean polished. Selectively broadcasting less refined livestreams—like lo-fi unboxing videos—can make your current customers feel more connected with your brand.

✓ Collaborate with influencers and creators

Half of surveyed merchants⁶⁷ plan to work with influencers to develop co-branded products next year. Influencers can engage a broader audience and enable product cross-promotion. Influencers also have high trust with their audience. For example, 89% of Youtube viewers⁶⁸ trust the recommendations YouTube creators provide.

✓ Make sure you have inventory available

Successful livestreams will lead to high short-term demand for your products, so be ready. Coordinate with your ecommerce teams ahead of your livestreams to have enough product in stock to meet increased demand.

RECOMMENDATION 2

Design a social commerce experience that converts

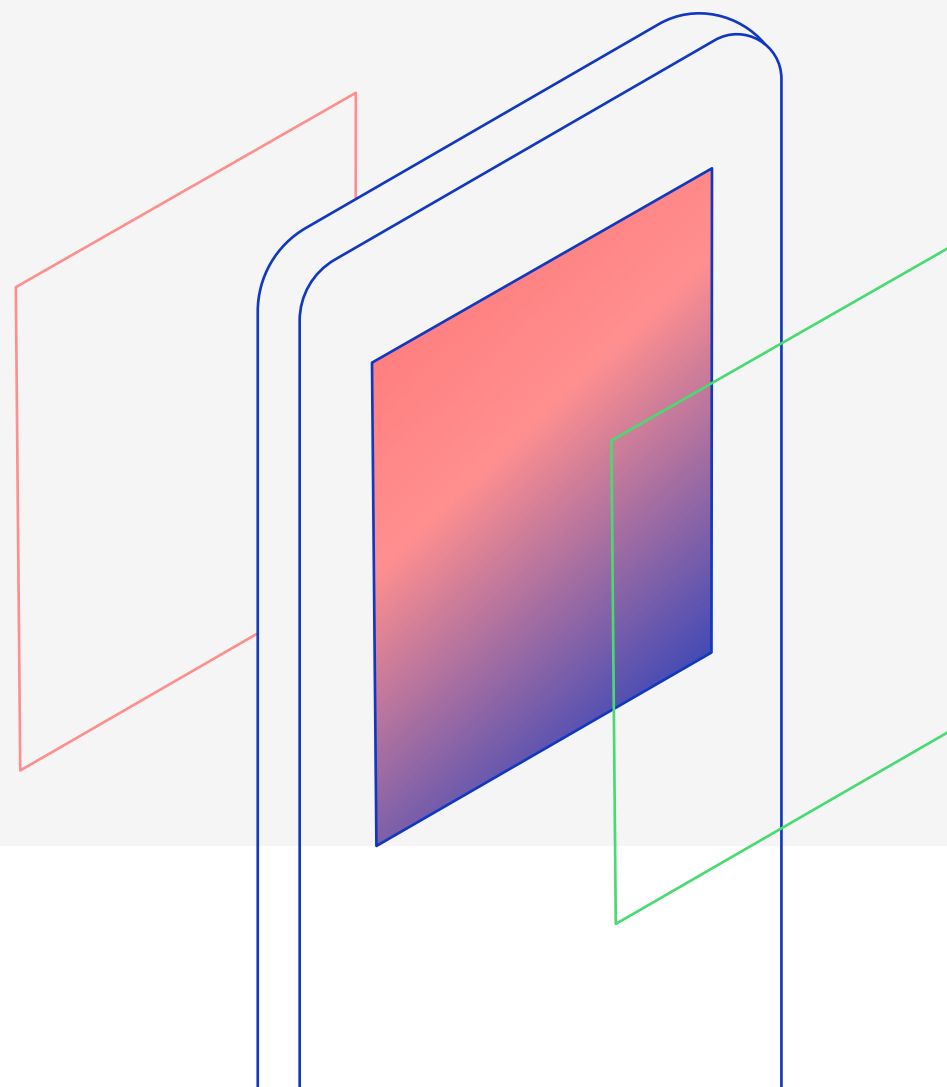

Create a social storefront

Craft your social storefront with care, whether that's replicating your website experience to provide familiarity, or curating top-performing products to feature on social media. Then encourage social sharing with exclusive discounts, promotions, or contests.



Format your videos so they're shoppable

Stick to one or two products per video and show them in action. Film with interactivity in mind, providing clickable calls to action throughout the video. Shoppable videos are still new to some viewers, especially those outside Southeast Asia, so let your customers know that your videos are shoppable.



Develop a shoppable attribution model

Use shoppable video ads for a clear view of conversion data, including click-to-view, click-to-buy, and click-to-share interactions.

Because every attribution model is only an approximate picture of how each touchpoint affects a customer's path to conversion,⁶⁹ use a combination of data sources to validate your top-performing channels and activities. Besides using UTM parameters in Google Analytics to study your users' behavior flow, look at your ad account data, study your click journey, and ask customers how they found you with app integrations like [Enquire Post Purchase Survey](#).

MERCHANT SPOTLIGHT

Glamnetic uses videos and livestream shopping to expand its reach

Glamnetic, a DTC beauty brand that can also be found in retail stores like Sephora and Ulta, has built up a loyal online audience—the Glam Fam—through its Facebook group and Instagram followers. The brand’s social channels started with founder and CEO Ann McFerran inviting her audience into the process of building the brand with videos explaining how the product worked and how it was different from competitors.

“The videos blew up and became really popular on social media,” McFerran says. Just three years later, “I would say we’ve hit a lot of female U.S. audiences at this point but I wouldn’t say we’ve reached even close to 10% of the rest of the world. So we’re setting our sights on that right now and seeing how we can expand our markets, because I think there’s a lot of low-hanging fruit there.”

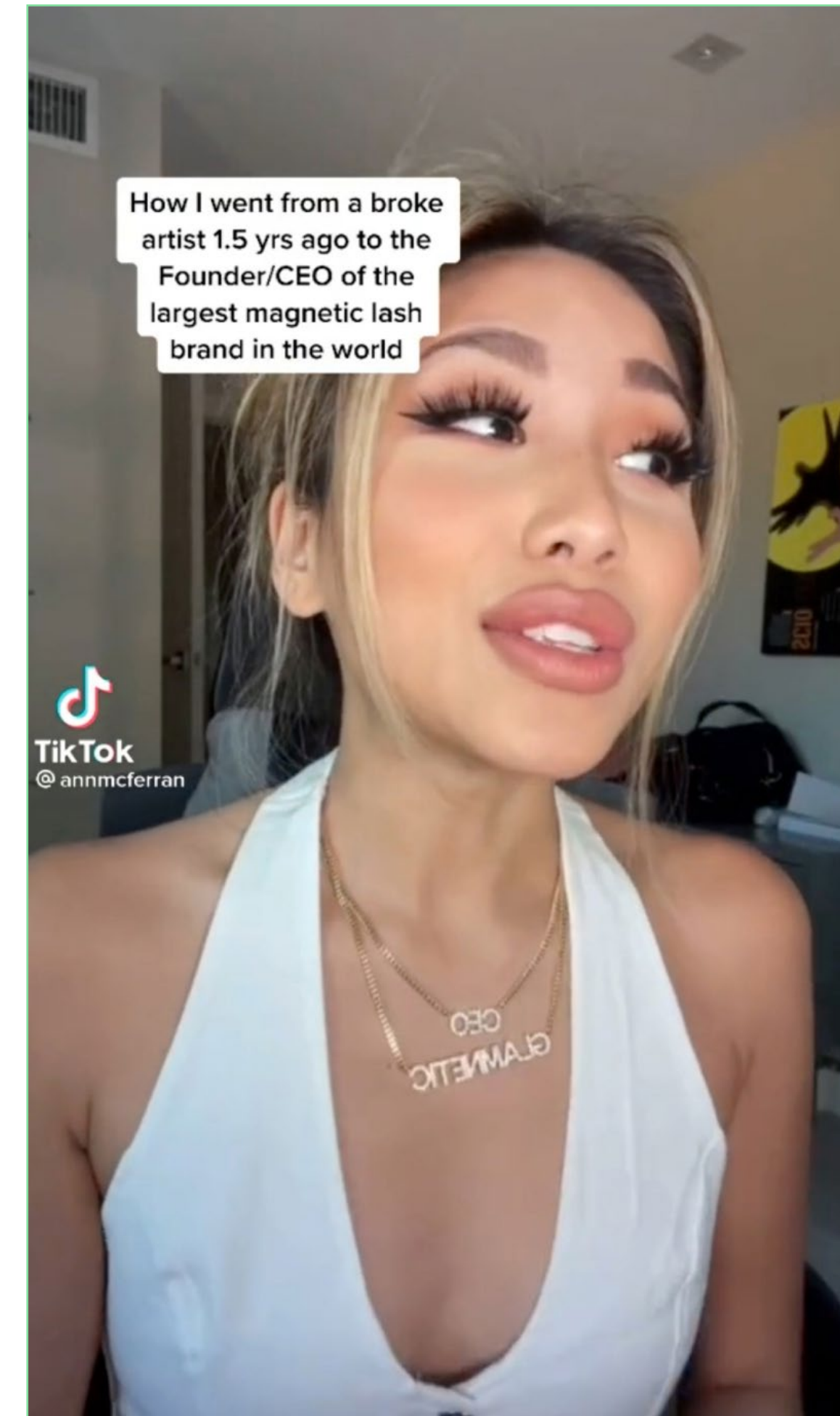



“

“[In China,] they’re selling \$30,000 vehicles through live shopping. We’re behind.”

Ann McFerran
CEO, Glamnetic

When it comes to connecting with this expanding audience, they’re going all in on live shopping, which combines the experiential elements of shopping in real life with your besties or, in this case, well-loved makeup artists and influencers.

“We already have a head of live shopping and she’s setting up multiple Facebook Lives on a daily basis,” says McFerran. “We’re on the precipice, and so we’re strategizing: How can we continue to improve and get even more revenues through that platform?”

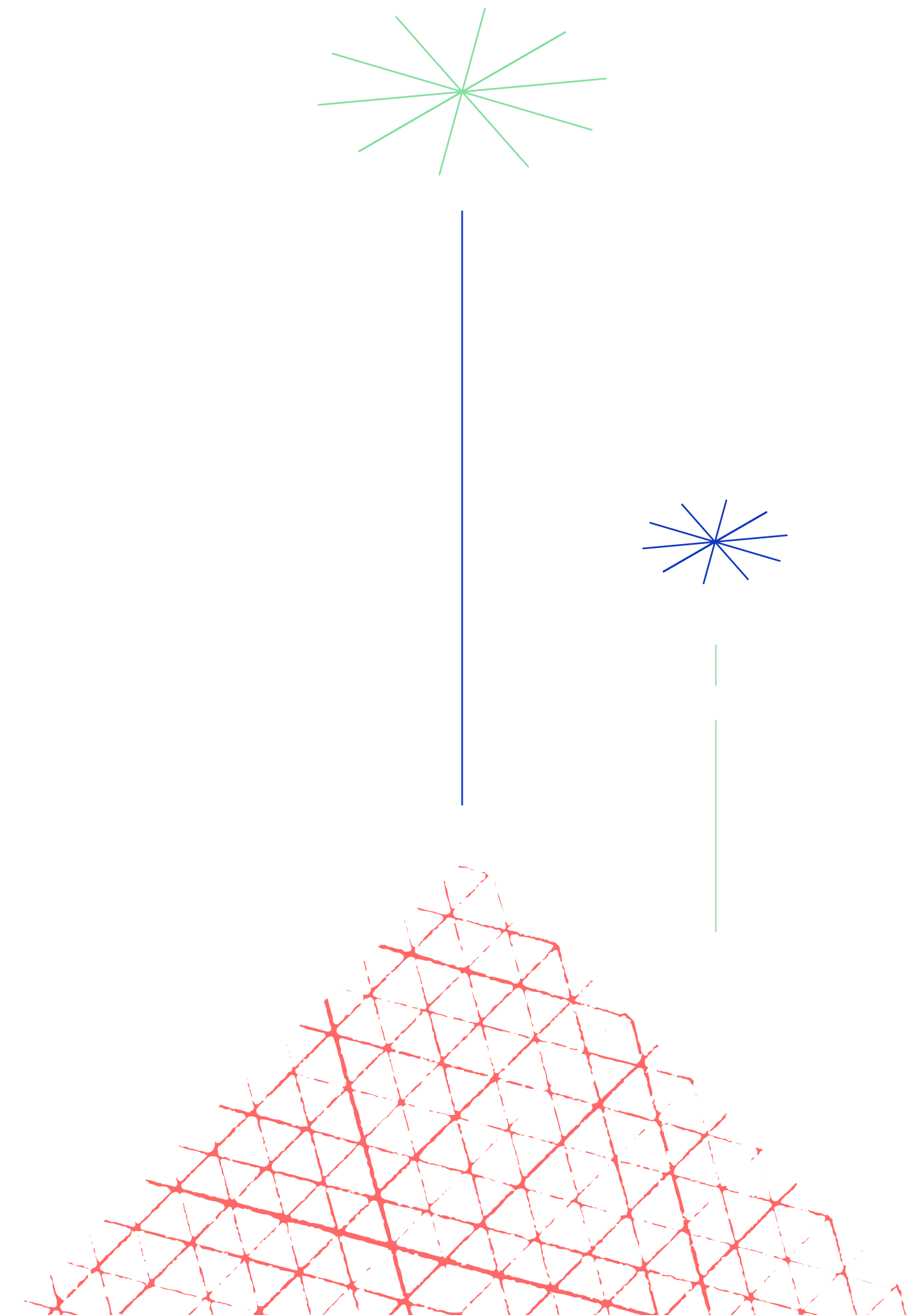

How Shopify can help

Optimize campaigns across social media

- Create, run, and optimize your social campaigns across TikTok, Instagram and Facebook—right from the Shopify admin
- Get insight into which products, images, and messaging resonate most with your audience with social data across channels and regions
- Turn those insights into action items for targeted marketing and cross-selling across your customer segments

Turn followers into customers with social media selling →

Make your content shoppable

- Improve brand and product discovery by showcasing your products on livestream shopping events, and create checkout moments on every major social channel, including Facebook, Instagram, Snapchat, Pinterest, TikTok, and WeChat
- Sync your product catalog with your business accounts, so users can make purchases directly on social media
- Increase product discovery and conversions by tagging your products in TikTok videos, as well as Facebook and Instagram images and stories

Sell your products on TikTok with Shopify →

Future of Retail

The retail trends, insights, and advice you need to succeed in 2022

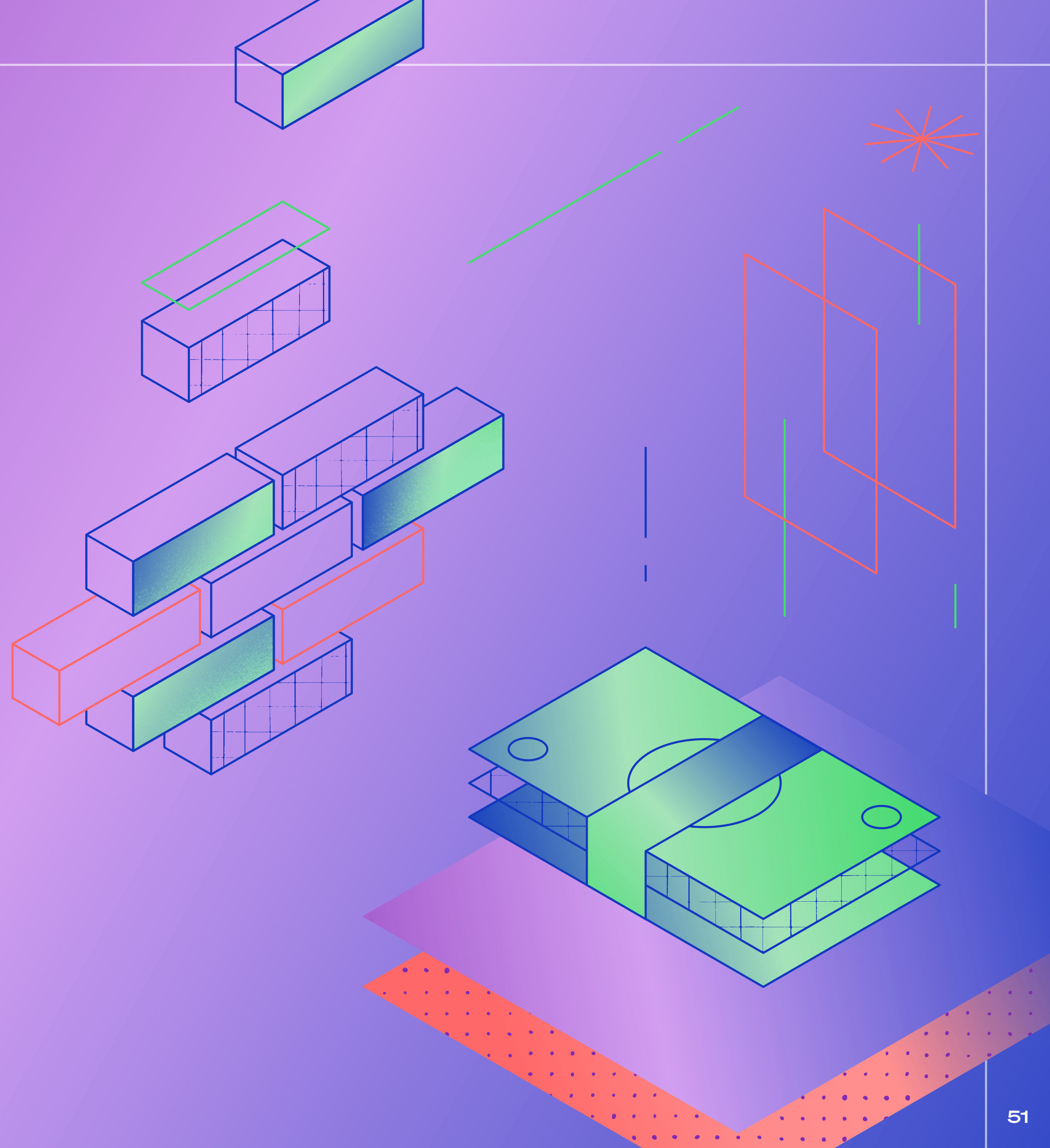

EXECUTIVE SUMMARY

The massive changes that 2020 brought to the retail industry are here to stay. And now that parts of the world are opening up, and consumers are craving opportunities to shop in person, they expect the buying experience to be consistent both online and off.

Increased retail vacancies have created an opportunity for a new wave of digitally native brands to experiment with physical retail. The surge of brands into offline channels means retailers must focus on creating engaging and memorable experiences to win foot traffic.

As a result, businesses must level up their omnichannel strategy to deliver a smooth shopping experience across channels. But to do this, employees need training in new technology like virtual shopping, live chat, and tools to manage alternative order fulfillment options like curbside pickup.

As the role of the retail store employee evolves, staff are demanding higher compensation and better working conditions. Retailers need to adapt if they want to attract and retain employees who are happy, engaged, and excited to meet customer expectations.

These changes demand new retail strategies to thrive. That's why we've collected global, data-backed insights from hundreds of retail brands and thousands of consumers to get the full picture of what's in store for 2022, as well as the strategies and products your business needs to succeed over the next year.

Welcome to the future of retail.

TREND 1

Digitally native brands drive retail competition

Merchants will prioritize experiential retail to drive foot traffic and customer loyalty

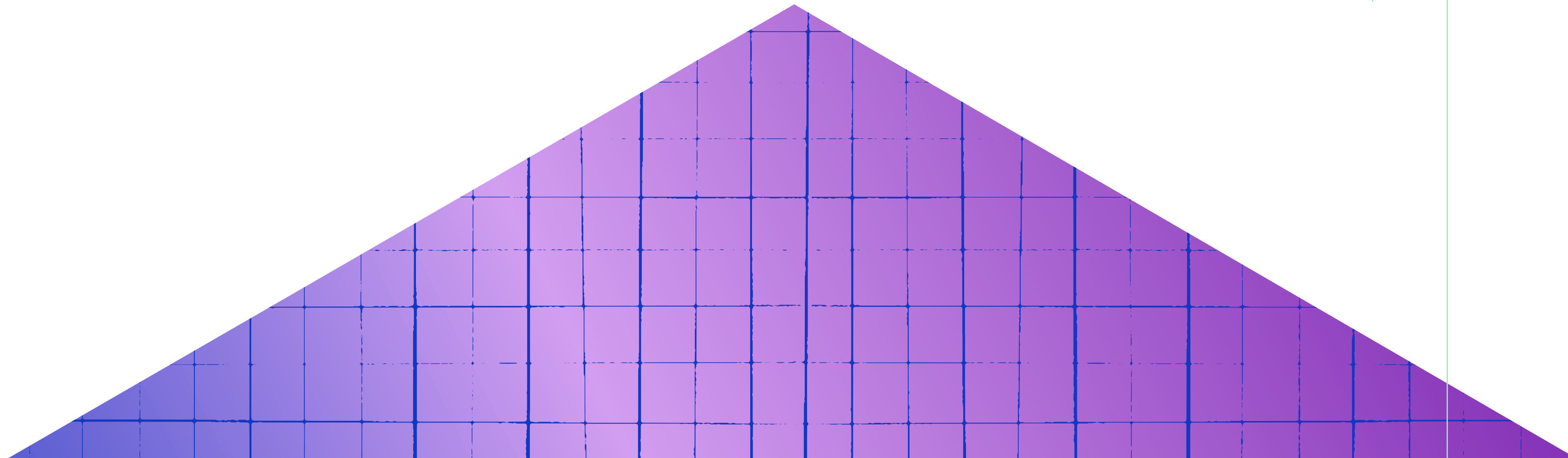

KEY TAKEAWAYS

Consumers are craving in-person shopping experiences

Consumers are craving the in-person experiences they've been missing, and brands are investing in experiential retail despite the fact that it could prove logistically difficult.

Favorable lease terms are tempting direct-to-consumer brands into brick and mortar

Higher retail vacancy rates are leading to more favorable commercial lease terms that might lure digitally native brands to venture into the world of physical retail.

Physical retail becomes an affordable acquisition option

Rising digital advertising costs will cause many brands to look to physical retail as a form of advertising to lower customer acquisition costs.

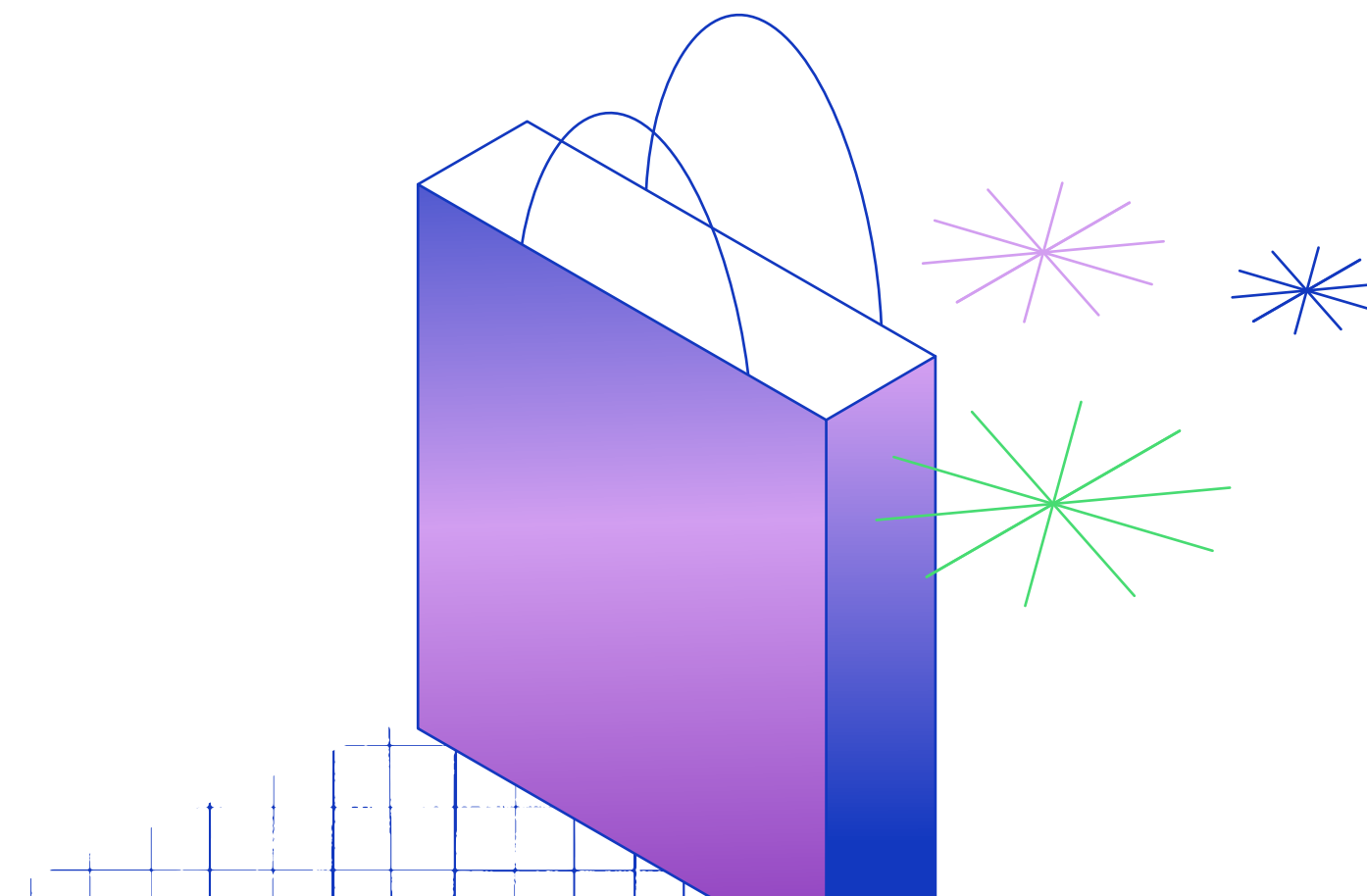

Demand for in-store shopping is on the rise

In-store shopping is ramping up again⁷⁰ now that stores have begun to reopen following lockdowns, vaccination rates are on the rise, and consumers are hungry for in-person experiences.⁷¹ As a result, 32% of brands⁷² said they'd be establishing or expanding their use of pop-up and in-person experiences in the next year, while 31% said they planned on establishing or expanding their physical retail footprint. And we're already seeing physical retail making a resurgence. In fact, sales growth on Shopify's POS outpaced ecommerce throughout 2021.

+22%

growth in global number of merchants using Shopify POS

Sourced from Shopify data, 2021

To stay competitive, 40% of brands⁷³ said offering experiential retail would be a top priority for them in the next year, something 32% of consumers say they are likely to engage with.

With retail vacancy rates at an all-time high,⁷⁴ we're in a tenant's market, meaning now is a better time than ever to negotiate more favorable commercial lease terms, including shorter contracts.

This will lure many digitally native brands, struggling with rising digital acquisition costs and an increasingly crowded ecommerce space,⁷⁵ to use physical retail as a way to offer a consistent brand experience across all channels. To win over customers, in addition to being strategically located, brands will need to focus on creating interesting and unique experiences in store.



The acronym 'DTC' also includes sales through stores that you own. What few consider is that customer acquisition costs are typically lower in owned, physical footprints. But for it to work, the brand must be strong.

Web Smith
Founder, 2PM

This influx of brands into the physical retail space will increase overall competition. Retailers will need to think about their storefront as their brand proposition, and embrace competitive differentiators like experiential retail to win foot traffic and customer loyalty.

Increased competition in physical retail means brands must create unique experiences to stand out

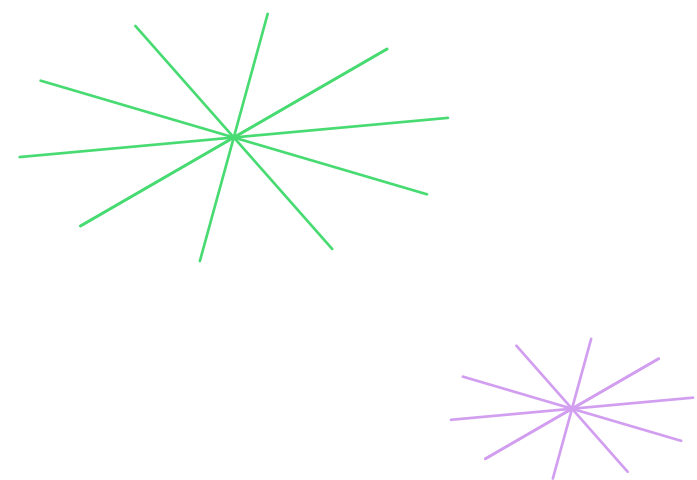

Just as the pandemic caused ecommerce competition to skyrocket, consumers' increasing appetite for in-person shopping experiences will boost competition in physical retail. Retail brands will need to focus on creating exceptional in-person shopping experiences to stand out, but approximately 57% of retail brands⁷⁶ said coordinating experiential retail would be a top challenge in the coming year, especially with 95% of consumers expecting retailers to have COVID safety protocols in place for customers shopping in store.⁷⁷

Digitally native brands might be at an advantage when it comes to experiential retail, since they'll be building experiences as an extension of their already-established online reputation and community.

"The quick feedback loop that's available for ecommerce brands helps them develop a really strong relationship with the customer. Starting with building your brand online can set you up for greater success when moving into physical retail."

Jack Meredith

VP of Marketing, Kettle and Fire

55%

of brands say another top challenge will be increasing foot-traffic to their stores

Shopify eCommerce Market Credibility Study, 2021

Coordinating in-store experiences will also be challenging for brands that have a substantial ecommerce arm to their business. These merchants will need to figure out how much of their retail space to use for experiences and how much to dedicate to holding inventory that's being sold through their online store.

Cracking the foot-traffic code will be another top challenge according to 55% of brands.⁷⁸ While increasing in places like the United States⁷⁹ and the United Kingdom,⁸⁰ foot traffic is still not back up to pre-pandemic levels.

Lastly, urbanization will play a key role in the future of retail. In 2020, 56.2% of the world population lived in urban environments⁸¹ and the United Nations projects this number will increase to 68%⁸² by 2050. This means more brands will compete in dense, urban areas, and will have to come up with strategies to succeed in smaller retail store spaces.

“

I see merchants using more of their space for inventory that's going out the back door through their ecommerce channel, as opposed to the inventory that's going out the front door to their retail foot-traffic audience. These are challenging decisions for merchants to make.

April Underwood
Founder and CEO, Nearby

Brick-and-mortar stores reach more customers while reducing acquisition costs

Digitally native brands that get brick and mortar right will not only unlock a large (and growing) segment of consumers who prefer in-person shopping, but they can also lower their customer acquisition costs, as did the brand [Lively](#).

A physical retail store is an avenue for connection and community, and provides the opportunity to attract more local customers. Forty-seven percent of consumers⁸³ said having a local presence was a significant or very significant influence on which brands they chose to purchase from in the past year.

Percentage of consumers who are significantly more likely to buy from brands with a local presence

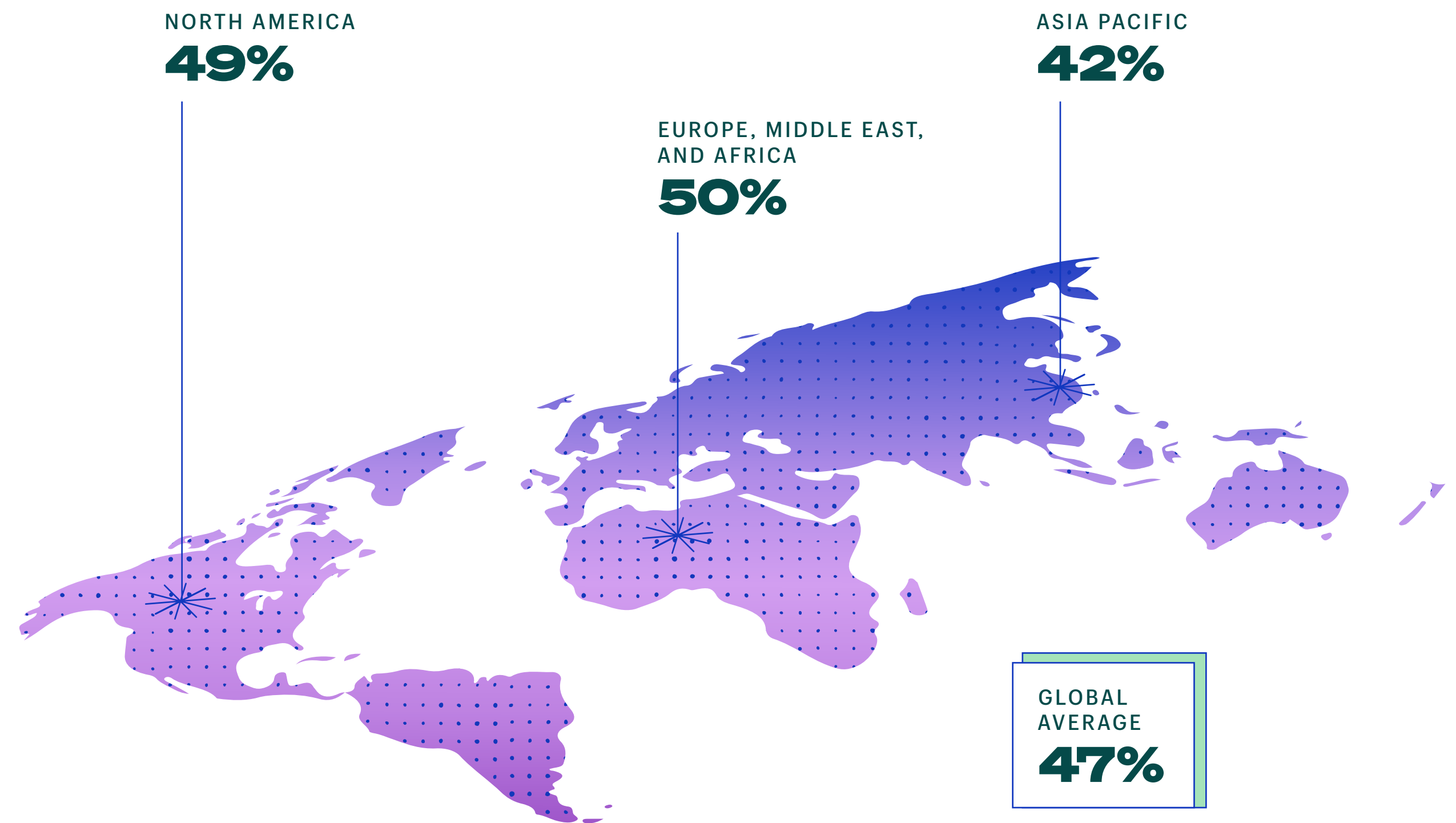

Sourced from Shopify eCommerce Market Credibility Study, 2021

And more than one-third of consumers⁸⁴ in the United Kingdom, Australia, and New Zealand say a sense of community is a top motivator to visit local shops.

In the United States, 81% of Gen Z consumers prefer to shop in store to discover new products,⁸⁵ and more than 50% say in-store browsing is a way to disconnect from the digital world.⁸⁶

And while 47% of retailers are concerned that securing affordable commercial leases will be one of their biggest challenges,⁸⁷ the harsh reality of global brick-and-mortar store closures⁸⁸ has also created an opportunity for a new wave of retailers to succeed. Lower rents⁸⁹ and shorter leases⁹⁰ mean you can more easily try out physical retail and new markets.



So many businesses have closed, so there's a lot of availability, and a new wave of really cool, interesting businesses are going to pop up. It's a great time to think about expanding into a physical space.

Kimberly Smith
Founder, Marjani and Board of Directors, National Retail Federation

81%

of Gen Z consumers in the United States prefer to shop in store to discover new products

How Gen Z's concern with emotional health fuels retail growth and culture, Kearney

RECOMMENDATIONS

How to create experiential moments that win over customers

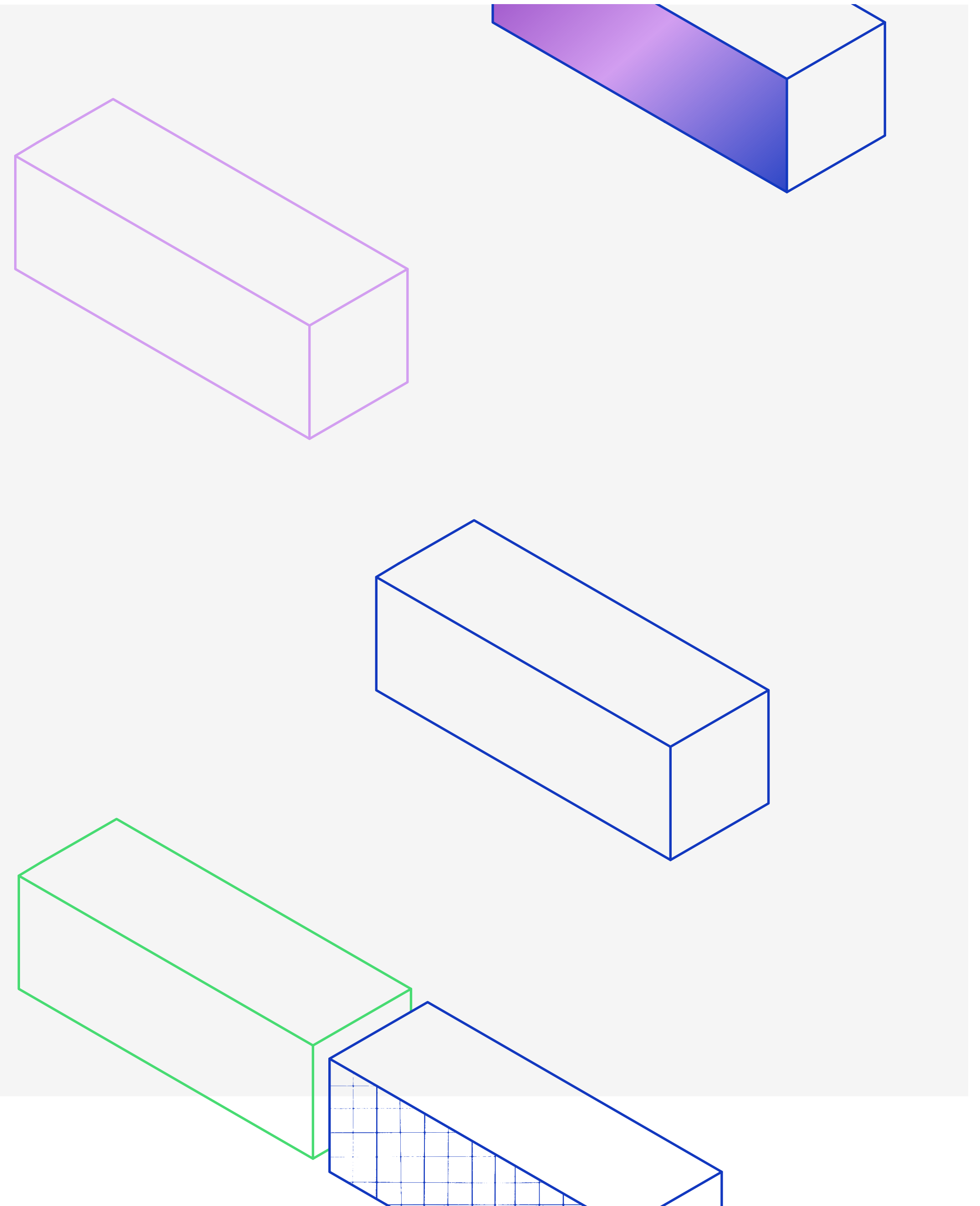

RECOMMENDATION 1

Use pop-up shops to test consumer demand for physical retail



Analyze customer data to test and learn

Exploring [experiential retail](#) doesn't mean you have to go directly from online to opening permanent retail stores. You can start small and apply your learnings from [pop-up shops](#) to your expansion strategy. Use the abundance of ecommerce customer data at your fingertips to drive your physical retail decision making, including where to pop up and what types of products to sell.

Analyze your ecommerce dashboard to understand where the bulk of your new and repeat customers live and what they're buying. Then use this data to localize your product assortment and experiences. Try testing a pop-up in these locations, and where you're most successful, consider opening a permanent storefront.



Find the pop-up format that's right for your business

- **Pop-in stores:** You can temporarily rent space within an existing brick-and-mortar store for a weekend, a week, or longer. It's key to partner with retailers who reach a similar target audience.
- **Pop-up events:** Emerging and established brands attend pop-up events to reach new audiences, build brand awareness, and boost sales. This setup is great for exposure because of the combined marketing efforts.
- **Leased commercial space:** If you've found success with pop-up shops and are looking to expand into your own retail store, getting your own short-term [retail lease](#) is a perfect way to test the waters.

RECOMMENDATION 2

Invest in creating unique in-store experiences to build brand affinity



The customer data you've collected online will help you strategically create experiences as an extension of your digital presence and community. Building a sense of belonging is easier to do in a physical environment, and can encourage customers to buy into your brand versus just the products you sell.

You can do this by creating community-focused spaces that offer events, workshops, brand collaborations, or support for charitable causes. Create memorable in-store experiences that align with your unique brand values, rather than just trying to increase sales revenue and boost your bottom line.

RECOMMENDATION 3

Use customer profiles to offer personalized recommendations



Integrate POS with your ecommerce platform

Fifty percent of consumers⁹¹ say that personalization based on their interests and past purchases have influenced their decision to purchase from a brand over the last year. Offering customized product recommendations or personalized product testing experiences is one way to achieve this in store. The key is to sync your customer profiles through a point of sale (POS) that integrates with your ecommerce website. This way you can easily review a customer's holistic purchase history.



Train your employees to improve the in-store experience

Training and preparing store staff to add this type of value to the in-store shopping experience will also keep them more engaged, provide opportunities to [upsell or cross-sell](#), and create growth opportunities—something that's crucial to retaining employees in today's retail landscape.

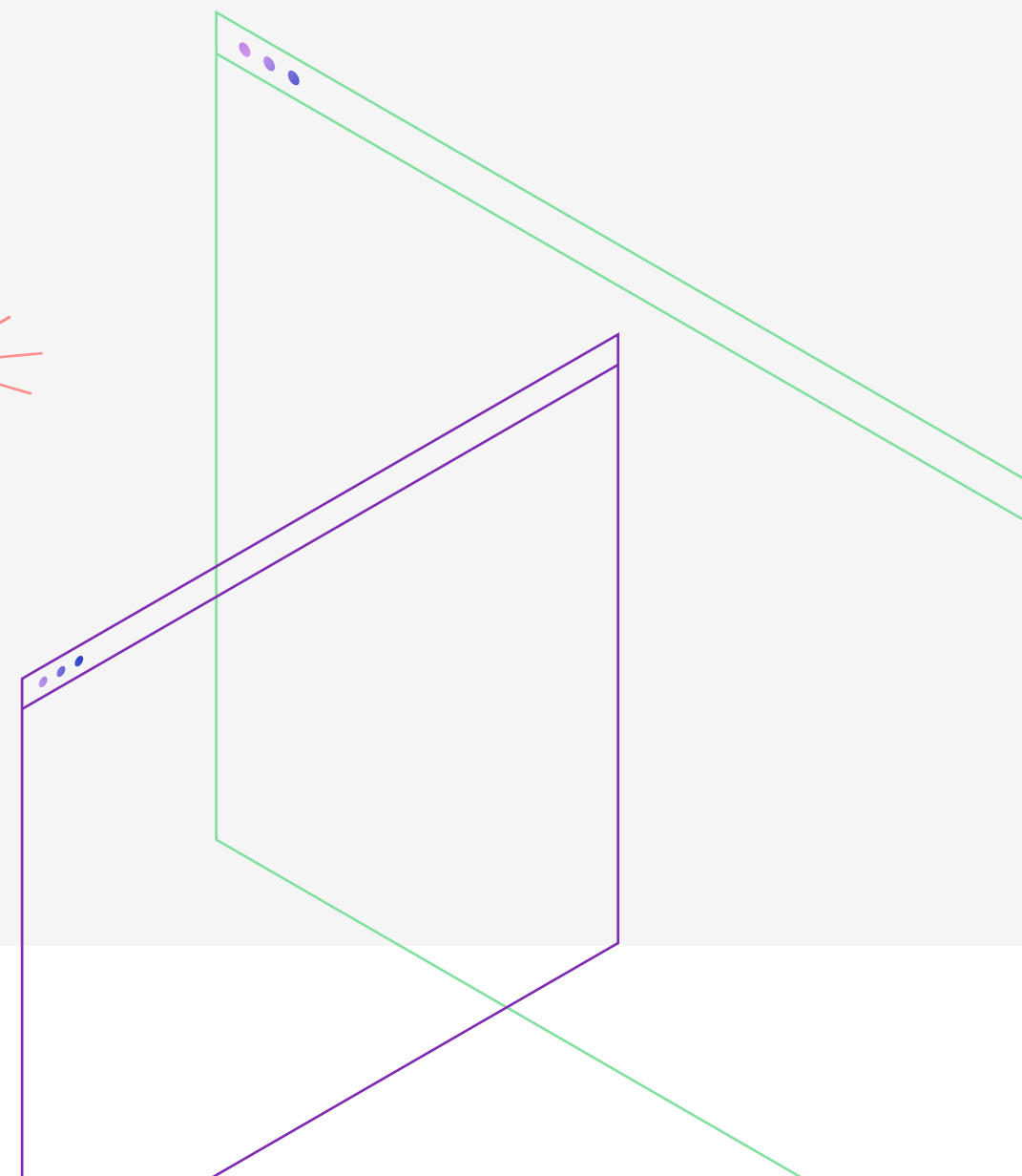
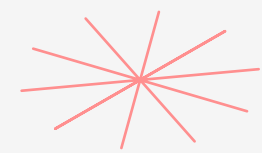

RECOMMENDATION 3

Offer in-store appointments

We've also seen an increase in Shopify merchants using appointment booking apps. For the period of January 1, 2021 to September 30, 2021, the number of installs for appointment booking apps increased by 23% globally, compared to the same time period in 2020.

This omnichannel sales strategy often involves stocking less inventory on the sales floor and using your space to schedule one-on-one or group appointments with shoppers, allowing for more personalization and room for in-store experiences.

One way to create this type of personalized experience is to set up testing stations and let customers make appointments to test new products before buying. Then have one employee equipped with a mobile POS manage each station. When the customer arrives for their appointment, your staff can pull up their customer profile and make personalized recommendations based on past purchases.



34%

**of consumers are likely to engage
with appointment shopping in 2022**

Shopify eCommerce Market Credibility Study, 2021

MERCHANT SPOTLIGHT

How Lively found success with physical retail



Lively was in a position that many digitally native brands find themselves in today: with steady sales and a loyal customer base, yet frustrated by the growing expense of acquiring customers online. Motivated by lowering costs, lingerie maker Lively opened a brick-and-mortar location. The brand went in with an advantage that many new brands, and even some established brick-and-mortar retailers, don't have: a thriving community that wants to engage with the brand in person.

Opening permanent locations not only helped Lively lower acquisition costs—about half of all Lively customers now discover the brand just by walking past the storefront—but operating both online and offline helped them increase average order value by a whopping 80%.

As we've seen from current retail vacancy rates, not all retail locations are successful. So what makes Lively different?



Our stores operate like billboards.

Michelle Cordeiro Grant
Founder, Lively

MERCHANT SPOTLIGHT

For one, Lively was smart about where they chose to open locations. They started by hosting in-person events in their brand ambassadors' home cities, then pop-ups. Through their first pop-up experiment, they learned that visitors didn't just want a showrooming experience. They wanted to leave with products in hand. That gave Lively the confidence that a more traditional retail setup was the way to go.

Next, they took what worked well with their online community to design their in-store experience. Lively has always been about community, so it was natural to bring this to retail. Store staff offer customers a beverage when they walk in, chat with them, and generally take a low-pressure, consultative approach to sales.

Finally, Lively used experiences like appointment shopping to increase in-store conversions and average order value, which is around 60%–80% higher for customers who book one of their “fit sesh” appointments. Customers fill out their personal details and schedule a time to come in for a bra fitting. Unlike the clinical nature of traditional bra fittings, Lively's staff tailors the recommendations and experience to each customer's unique needs.

Brick and mortar is far from a guaranteed success story. As shown by Lively, it requires strategy, community, and a standout experience. And that winning combination can deliver standout results.



“We opened a permanent location because we wanted a place where we could bring our community together. You want them to get to a place where it's like you're just hanging out with your girlfriend. You're more honest, open, and you're going to have fun.”

Michelle Cordeiro Grant
 Founder, Lively

How Shopify can help

View Shopify reports to find the right store location

You have the right product—now you need the right location. View the sales by billing location report in Shopify admin to pinpoint where your customers live. You can also view sessions by location reports to identify untapped markets where opening a retail store could help reach new customers.

Use Shopify POS to create customer profiles

Equipped with Shopify POS customer profiles that sync in-store and online purchase history, store staff can develop a rich understanding of the customers they serve, offer more relevant product recommendations, and increase basket sizes.

Increase foot traffic with online to in-store order fulfillment

Use Shopify's online to in-store fulfillment features to maintain a steady stream of foot traffic. Consider [displaying in-store product availability on product pages](#) and offering order fulfillment options like click and collect at checkout. For additional fulfillment strategies, check out the [Future of Shipping and Logistics](#).

TREND 2

The post-pandemic customer journey will bring about the next phase of omnichannel shopping

Retailers must integrate in-store and online experiences or risk extinction

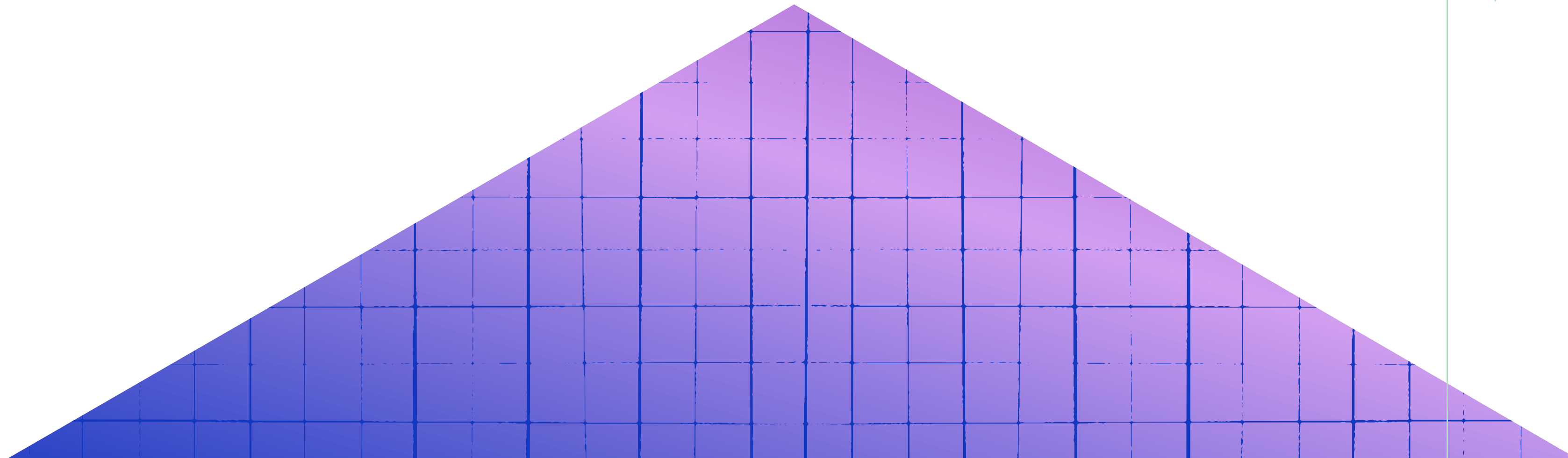

KEY TAKEAWAYS

Brands are staying competitive with omnichannel commerce

To stay competitive, brands must create experiences and build relationships with their customers that only omnichannel can offer.

Consumers are connecting with brands across multiple channels

Whether it's online or offline, consumer shopping expectations and buying journeys have changed and can start and end on any channel.

Consumers expect consistency across channels

To adapt to the next phase of omnichannel, brands must provide a consistent experience across channels.

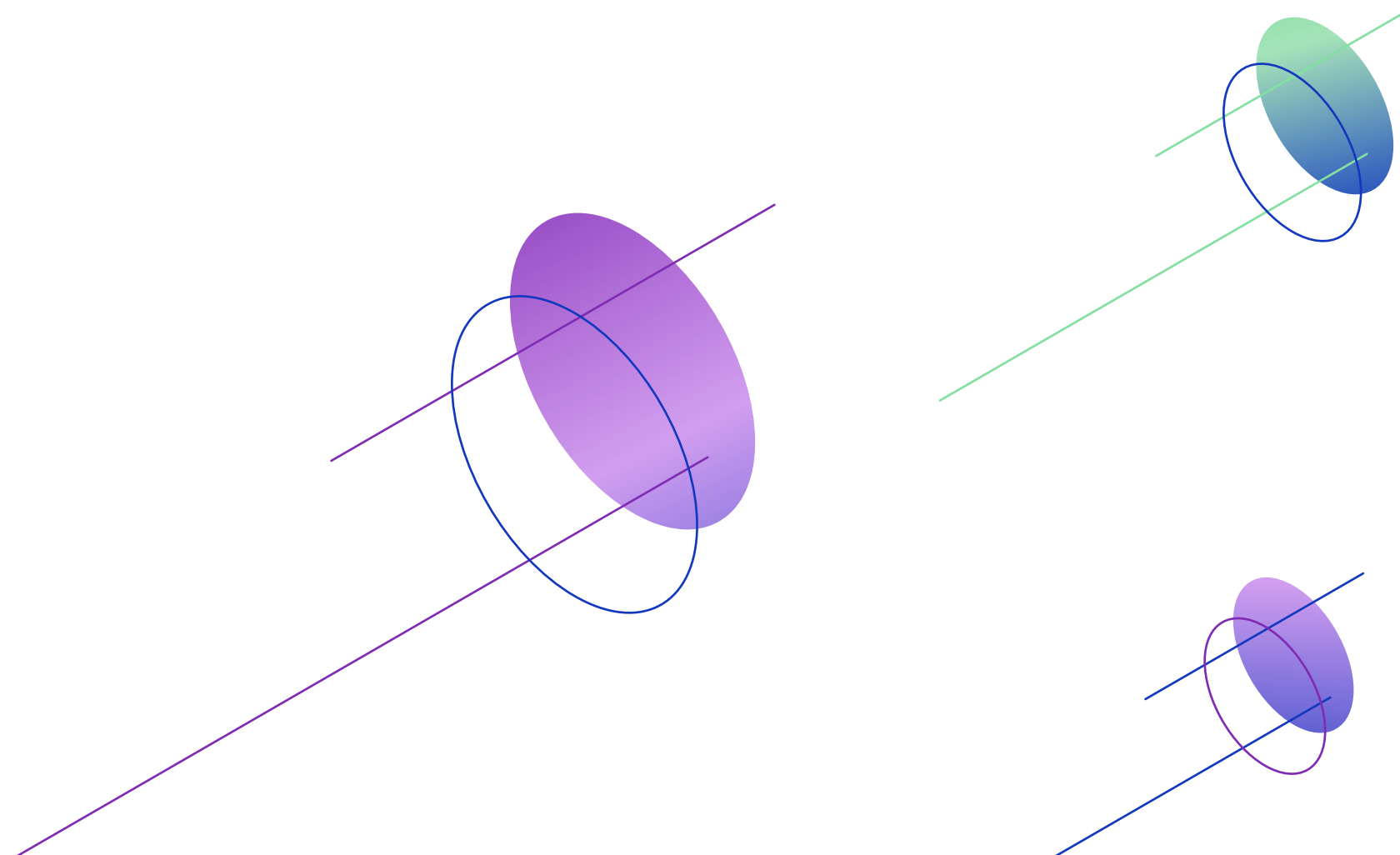

Omnichannel commerce surfaces as the new normal

As shoppers return to stores, the lines between buying online and in person have blurred. Fifty-four percent of consumers⁹² say that, over the next year, they're likely to look at a product online and buy it in store, and 53% are likely to look at a product in store and buy it online.

According to our research, consumer packaged goods and retail companies say sales from their physical retail stores and sales from their ecommerce website are nearly equal, with physical retail generating 18% of revenue and ecommerce generating 19%.⁹³

As a result, 53% of brands⁹⁴ are investing in tools that allow them to sell anywhere. This shift in consumer behavior, combined with the increased competition coming from digitally native brands moving into retail, means it's not enough to use the retail store for acquisition alone. Retailers must build relationships and experiences with their customers that only omnichannel commerce can offer.



Building relationships with customers is going to be the number one thing, not only through your website but all channels. Your brand presence and message have to be active and engaging across your website, email, and social. This is not only because acquisition is challenging, but also because brands will see the need to keep a dialogue going with their customers.

Robert Befumo
Head of Ecommerce Strategy,
Parkfield Commerce

After a year of shopping mostly online, consumer expectations have changed. Every buying journey is multi-faceted, and can start and end on any channel. For example, 55% of consumers⁹⁵ want to browse products online and check what's available in local stores. That's why over the next year, 43% of brands⁹⁶ will focus on showing available inventory in nearby stores.

Customers also want to check out online but return products to a physical store, or look at a product in store and buy online. For 47% of consumers,⁹⁷ these factors have a significant influence on their purchase decisions.

“Brands need to make it as easy and convenient as possible for their customers to shop wherever they find themselves. And in 2022 and beyond, that means providing an omnichannel approach to shopping experiences.”

David Wagoner
CEO and Founder, P3 Media

Percentage of customers who are significantly more likely to order a product if they can check out online and return in store

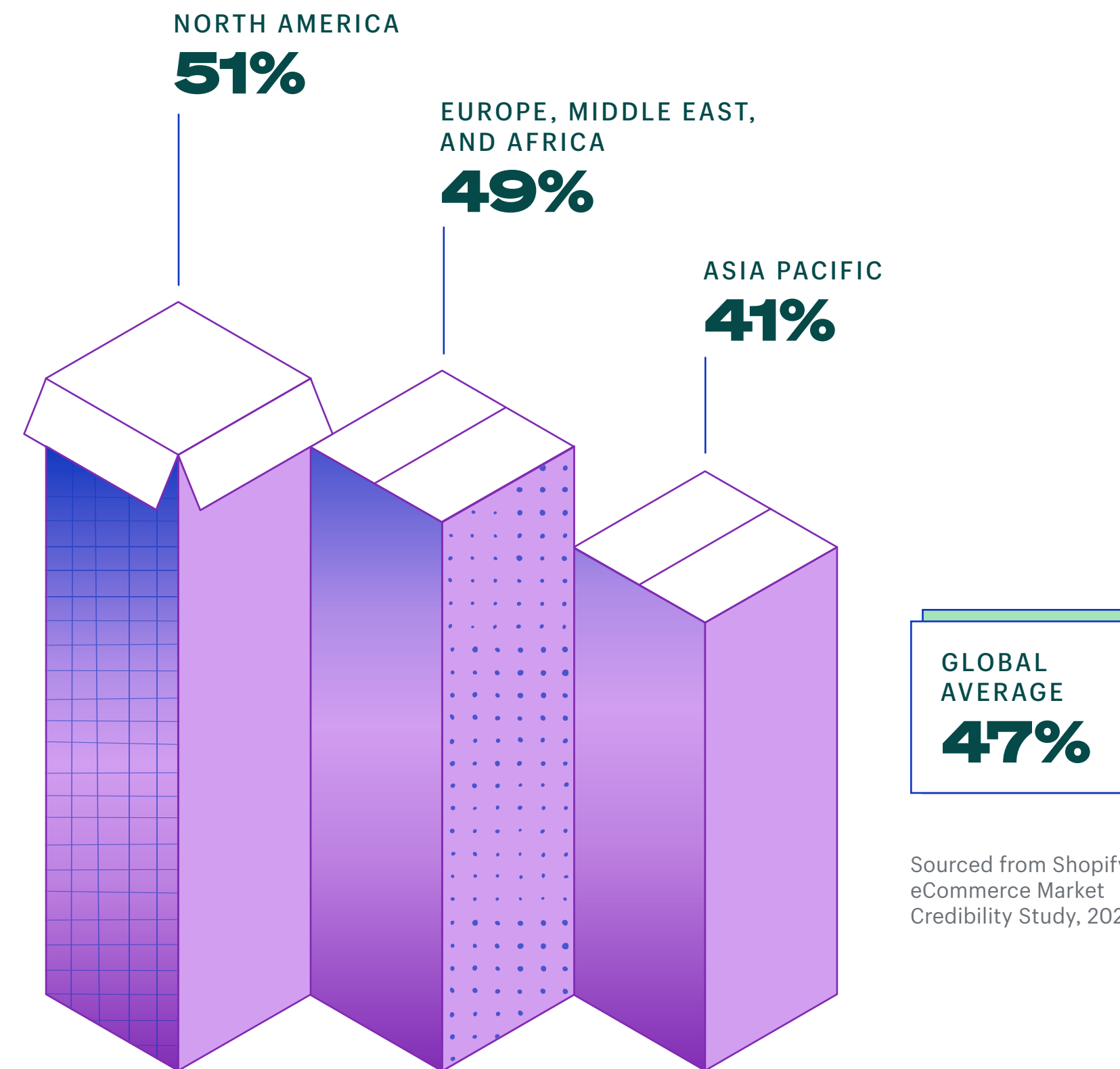

Brands will be challenged by higher customer expectations, more pressure, and the need to pivot to a retention mindset

Forty-nine percent of brands say breaking down organizational silos between digital and physical stores will be one of their biggest challenges over the next year,⁹⁸ and 47% of retailers say unifying online and in-store operations and data will also prove to be difficult.⁹⁹

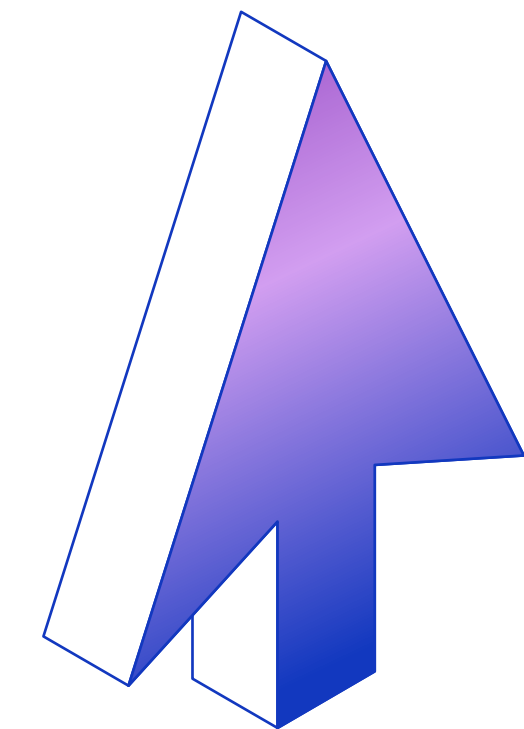
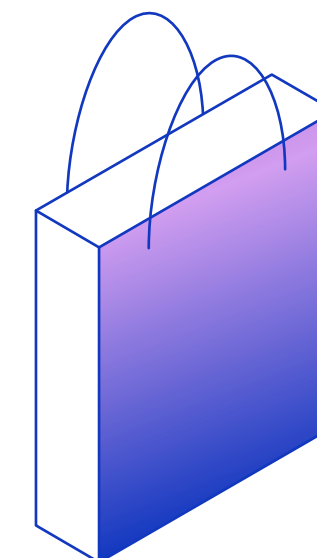

Top challenges retailers say they face over the next year

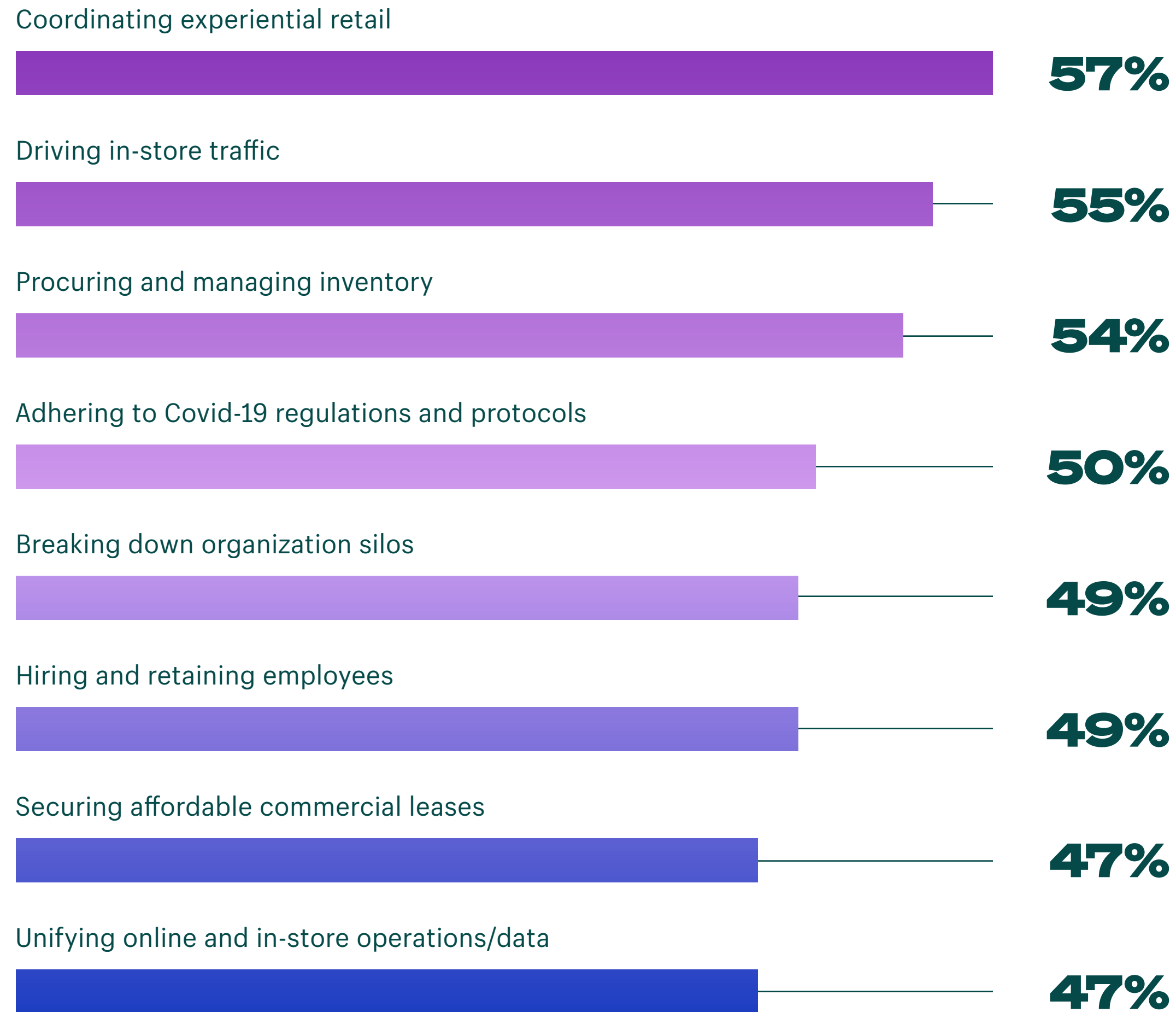

Sourced from Shopify eCommerce Market Credibility Study, 2021

Ecommerce brands moving into physical retail are also increasing the pressure on traditional brick-and-mortar retailers, who are often held back by legacy technology and infrastructure. Retailers are planning to increase their investment in digital channels to drive sales over the next 12 months. Forty-nine percent said they'll spend more on their company-owned online store as well as social commerce,¹⁰⁰ 46% on their custom mobile app,¹⁰¹ and 44% on livestream selling.¹⁰²



The future is neither ecommerce or retail. It's just commerce. So the question becomes, 'How do you symbiotically integrate both channels?'

Hemant Chavan
Founder, Brik + Klik

The right omnichannel strategy can increase average order values and customer loyalty

Brands that are able to embrace technology to unify channels and create an omnichannel strategy will have a competitive advantage that wins and retains more customers.



Accessible, affordable tech is opening up new opportunities for independent retailers because they can now do things themselves that previously were prohibitively expensive, or something only big box stores had the resources to offer.

Kimberly Smith
 Founder, Marjani and Board of Directors, National Retail Federation

Creating a fully connected [physical and digital](#) shopping experience, for example by implementing [buy online, pick up in-store \(BOPIS\)](#), will also help retailers increase their [average order values](#).

In fact, over 50% of adult shoppers use BOPIS,¹⁰³ with 67% adding extra items to their carts when they can pick them up immediately. Another advantage is that customers who buy online and return in store can be incentivized to make additional purchases when they return in store. These types of upsell opportunities are available to brands that think strategically about using their store in tandem with other channels.

“Some brands are viewing returns as an additional touchpoint, offering an extra discount at return if you use the store credit the same day.”

Kyle Monk
 Director of Insight, British Retail Consortium

RECOMMENDATIONS

How to succeed in the next phase of omnichannel commerce

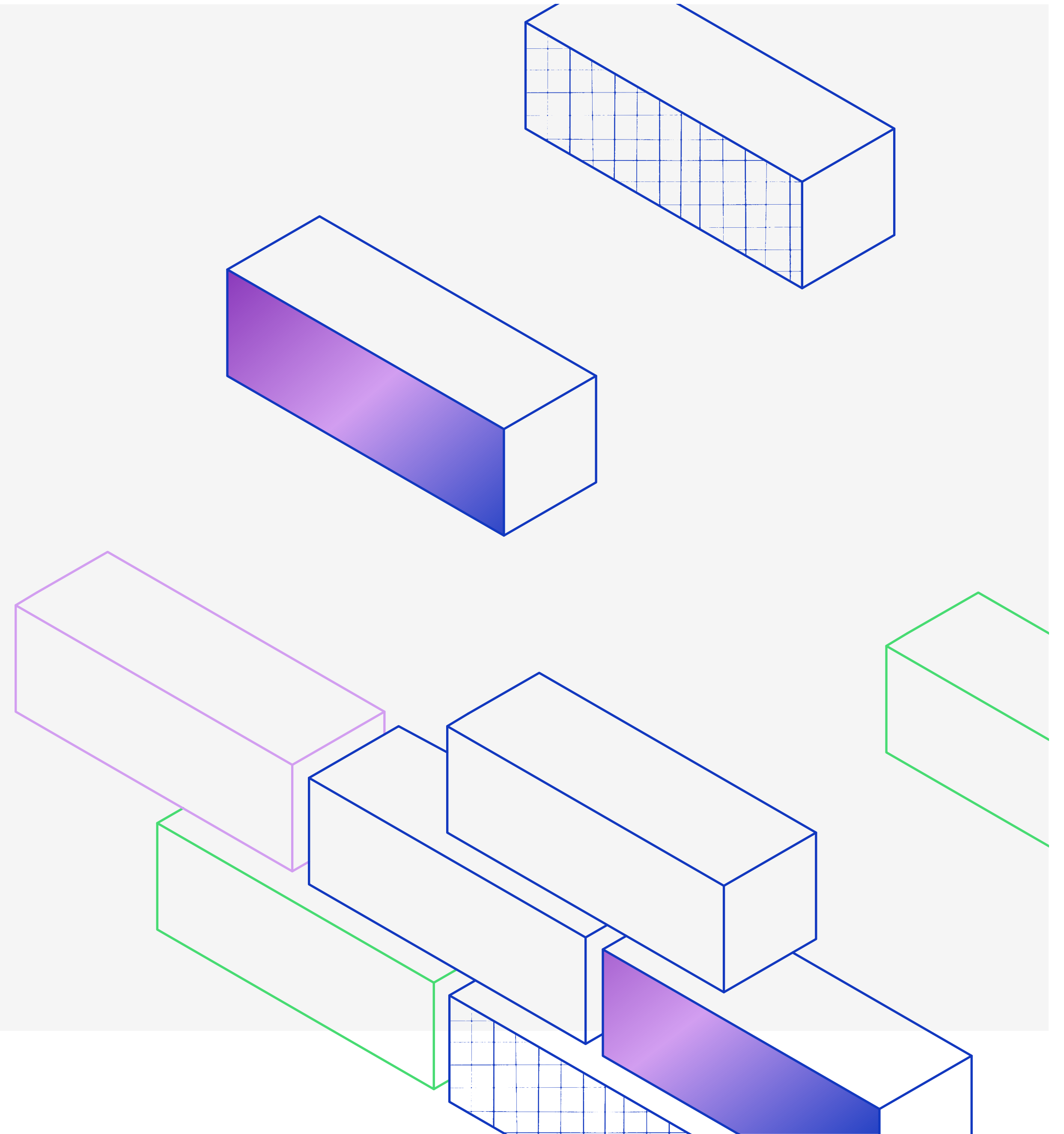

RECOMMENDATION 1

Turn your retail store into a showroom to improve brand discovery and awareness

When we asked retailers where they're investing to improve the in-store experience, the most popular answer was showrooming, with 46% of brands¹⁰⁴ saying they'll be investing in it throughout the next year.

[Showrooming](#) is all about allowing customers to come in and experience the product without having to buy or take home the product right then and there. If you want to try showrooming, there are two main things to consider:

Carry less stock in store

Completing the purchase online means you can [carry less inventory](#) in your physical stores, freeing up more space for experiential retail and customer interactions. Instead, you can opt to keep the bulk of your inventory in a warehouse.

Make sure the sale is connected to your physical store

The actual purchase may take place online with showrooming, but if the consumer discovered your product in store, you'll want to make sure the sale is attributed to your physical store. To do that, have your store staff check the customer out online while they're at the store, or [email the customer a unique checkout link](#).

RECOMMENDATION 2

Unify your customer and product data to provide a consistent customer experience across channels



Track product performance across channels

Providing a consistent customer experience across channels requires a unified view of your product and customer data. The best way to achieve this is to build and manage your business through a single platform that lets you manage all your sales channels from one dashboard. This way you can easily connect with third-party solutions and integrate data sources and workflows.

Use a commerce platform that integrates with the sales and supply sides of your business, and a POS system that connects your digital storefront with retail locations in a central reporting hub. Managing your business from one platform will also provide a single view of sales data and reporting. So whether it's in store, online, or on [social media](#), you can efficiently track product performance across all sales channels.



Sync your product information across channels

Use a platform that automatically syncs product information including price, descriptions, SKU counts, and images to make sure your product data and inventory levels update in real time and are always accurate across channels. Customers can then check what's in stock, sign up for restock alerts, and choose their preferred order fulfillment method, regardless of where they're shopping from.



Use brick-and-mortar locations as fulfillment centers

You can also use your brick-and-mortar locations as [fulfillment centers](#) to offer flexible, blended shipping options like BOPIS—something that 58% of consumers¹⁰⁵ say is important to them and 33% of brands are prioritizing over the next year.

MERCHANT SPOTLIGHT

How The Sheet Society prepared for the next phase in omnichannel shopping



All the data we need on our customers is right there in Shopify POS. Now we have a unified database that shares important context on customer preferences and inventory availability across all store locations, which helps us serve them better.

Hayley Worley
Founder, The Sheet Society

When customers think about your brand, they don't see an online brand and an offline brand. They just see your brand. It's a concept that's easy to understand, but much harder to put into practice. The Sheet Society gets this right.

The Australian bedding retailer is all about building strong customer relationships. To accomplish this, The Sheet Society centralized its customer data with Shopify, allowing store staff to view customers' purchase history and offer personalized service that reflects their online and in-person shopping preferences.

MERCHANT SPOTLIGHT

Building brand affinity isn't built exclusively online or in person. It requires a holistic approach to commerce. You need both your online and offline presence to develop it. The Sheet Society accomplishes this with an online store that's integrated with their brick-and-mortar store. This opens up unique workflows to convert more sales opportunities into revenue.

For example, they offer something called Bed Builder, an augmented reality tool that allows customers to use their iPhones to see how products look on their bed. In store, they offer take-home fabric switches and pre-booked bed styling appointments, and will make up a bed in store with a customer's chosen combination.

"If shoppers want to see how a style complements their existing bed, store staff [can] preload a shopping cart in Shopify POS and [email] it to them."

Hayley Worley

Founder, The Sheet Society



Unifying its customer data and sales channels has helped The Sheet Society increase customer retention as well as in-store conversions. Since using Shopify to sell both online and in person, The Sheet Society lifted its return customer rate to 24% and store conversion rate to 50%.

This next phase of omnichannel requires retailers to think beyond just selling in person and online. Instead, it's about blending your in-person and online presence to foster community, trust, and retention. Like The Sheet Society, brands that invest in these areas will be poised to succeed in 2022 and beyond.

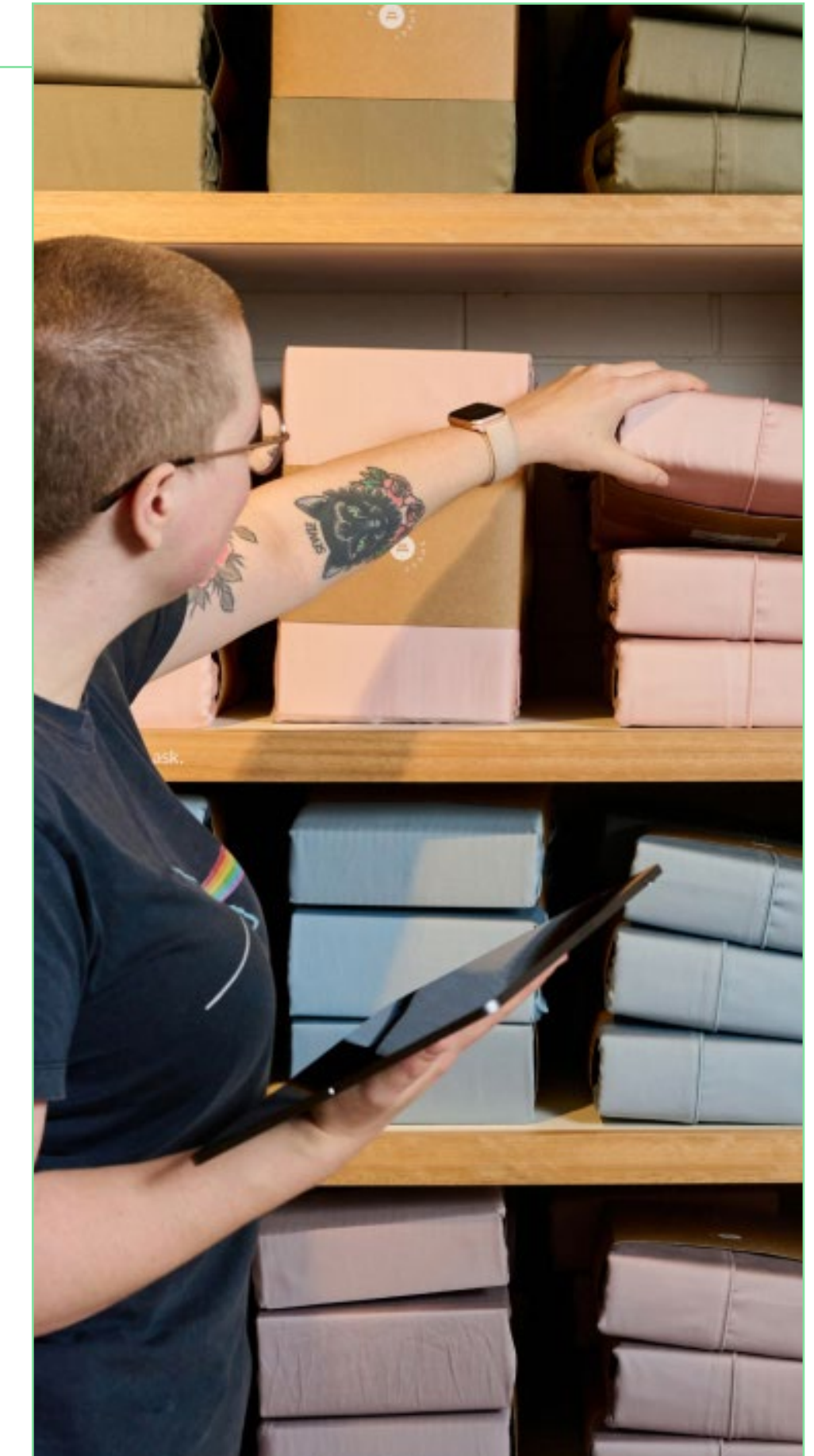

How Shopify can help

Unify in-store and online sales

Merchants that use Shopify have all the tools they need to manage their business, market to customers, and sell everywhere from the same powerful back office. Customer, inventory, product, and sales data is synced automatically and available in the Shopify admin. Whether products are sold online, in person, or on Instagram, Shopify acts as a single source of truth and helps you run your omnichannel business with confidence.

Attribute retail's contribution to online sales

One common challenge brands cite is crediting retail stores as the point of product discovery for online purchase. Here are just a few examples of how you can use [Shopify POS](#) to attribute sales to the right channels:

- With Shopify's Shopcode app, you can generate [QR codes](#) that let customers check out wherever they are in store. Use QR codes as physical buy buttons in window displays or on product packaging that direct customers to a product or checkout page.
- Store staff can create and email wish lists as they serve shoppers to encourage post-visit online purchases.
- If an item is out of stock, use Shopify POS to process the transaction in store, then communicate with the warehouse to ship the product directly to the customer.

Sell everywhere with Shopify →

TREND 3

Consumer and employee expectations push brands to reimagine the retail staff role

Brands that figure out staff retention will have the edge on customer retention

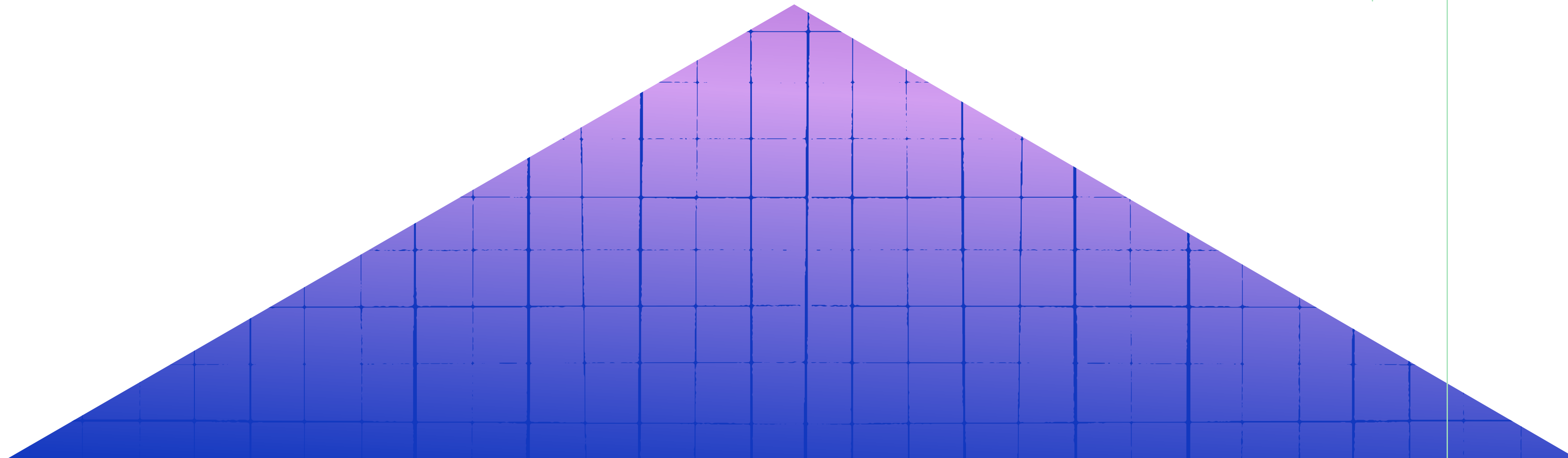

KEY TAKEAWAYS

Customers expect world-class service (from everyone)

Customer service expectations are higher than ever before, which means more responsibilities—and opportunities—for the role of store associate.

Brands are reimagining retail roles and compensation

Retail employees are demanding higher pay and more opportunities, so brands must reimagine the store staff role and compensation to attract and retain employees.

Technology is helping brands deliver consistent experiences

Brands are investing in employee training and technology to help staff deliver a consistent customer experience across all touchpoints.

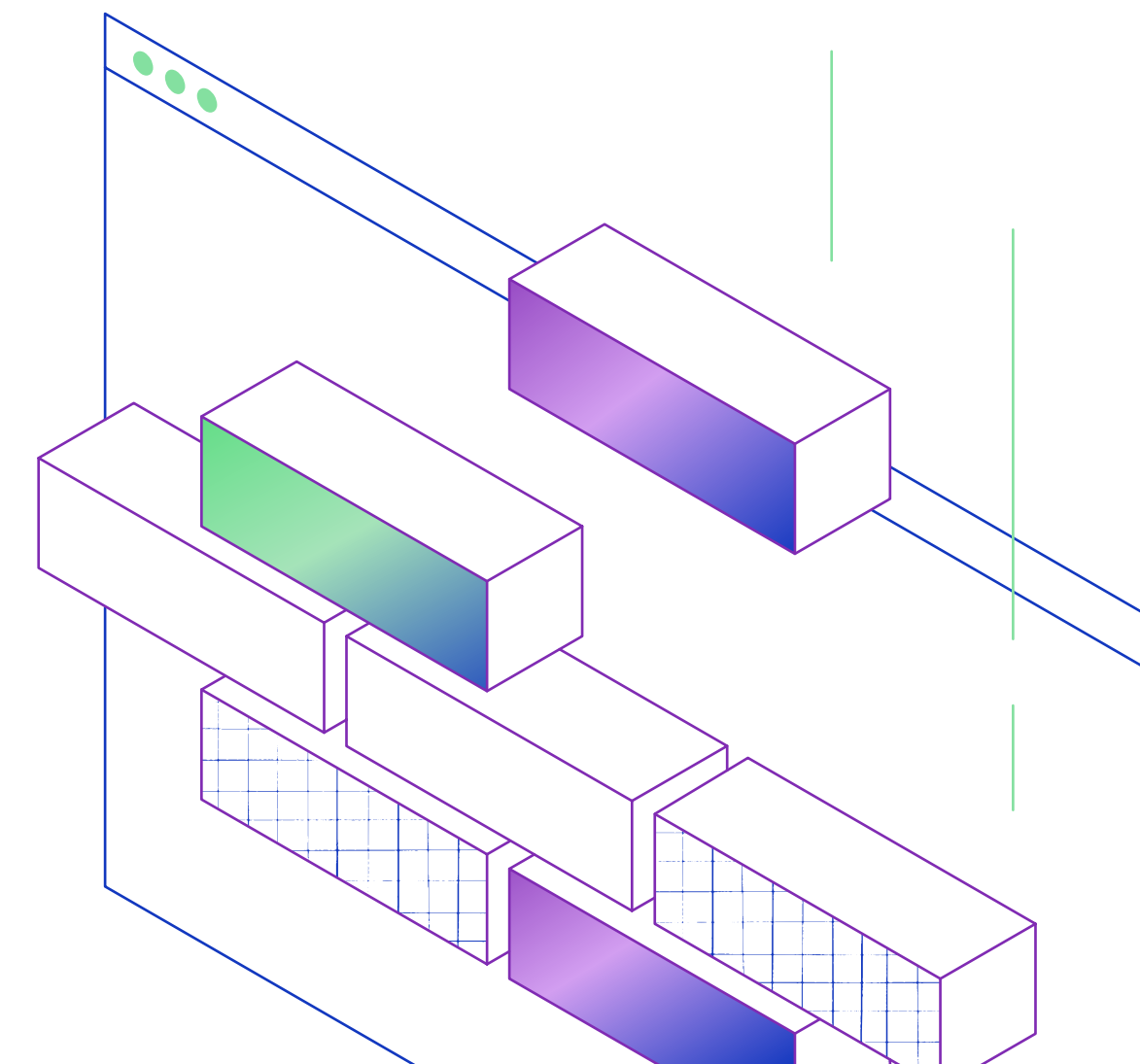

Brands reimagine the retail staff role with the rise of live chat and virtual shopping

Customer experience plays a big role in a shopper’s decision to buy. It’s the reason why 58% of consumers¹⁰⁶ made repeat purchases from a specific brand over the last year. In response, 44% of brands plan to increase their employees’ interaction time with customers over the next year.

But engaging with customers will go beyond traditional in-person interactions. Instead, store staff should act as experience hosts, facilitating options like virtual shopping, live chat, and appointment shopping. Thirty-nine percent of retailers say they’re investing in improving the tools and technologies employees use to do their day-to-day work.¹⁰⁷ This includes tools and apps to manage virtual selling, staff shifts, live chat—something 41% of consumers¹⁰⁸ say is valuable to them—[local delivery](#), and in-store appointments.

Percentage of consumers who say past customer service significantly influences their decision to buy

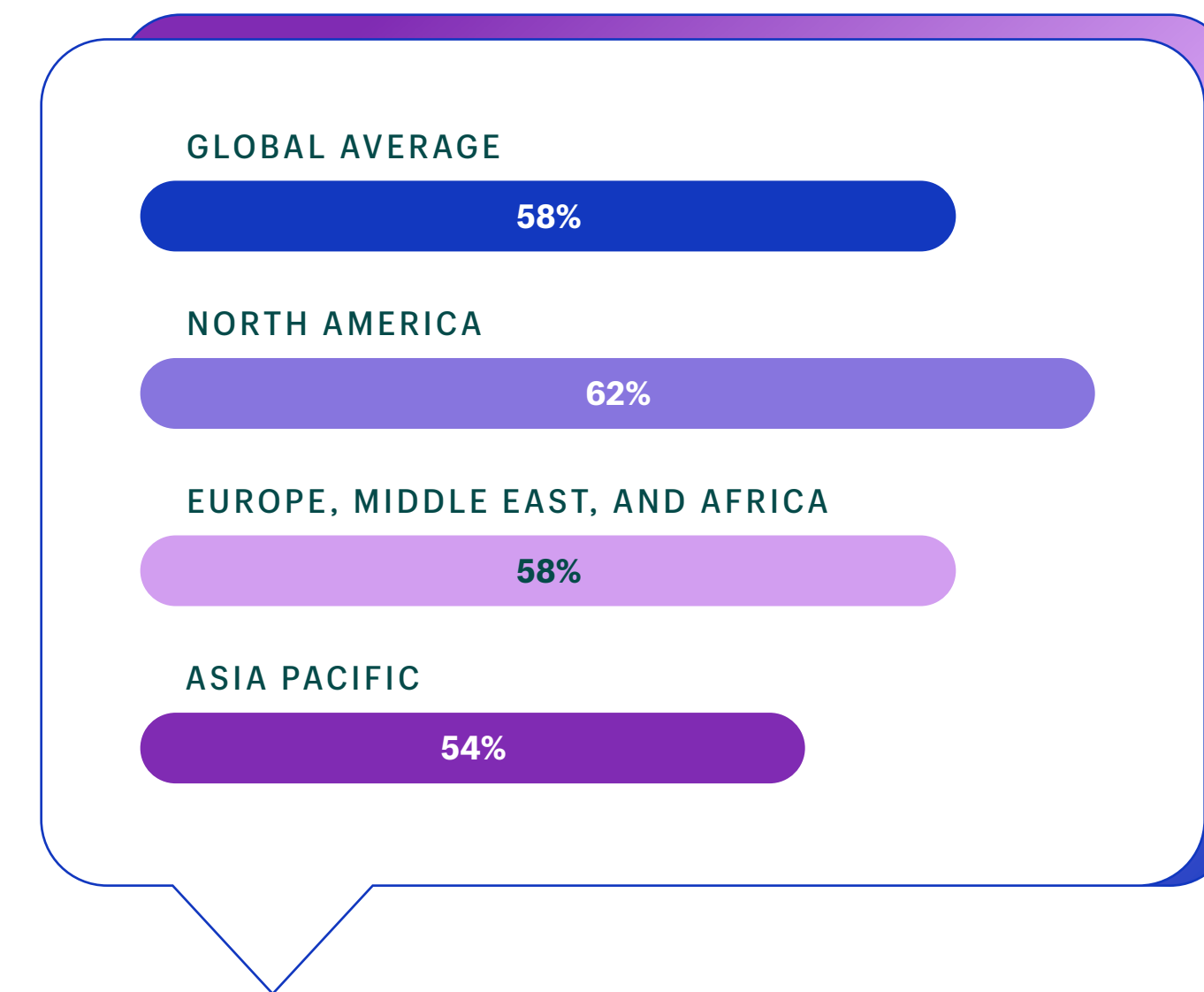

Sourced from Shopify eCommerce Market Credibility Study, 2021

Brands are investing in customer relationships through tools and technology

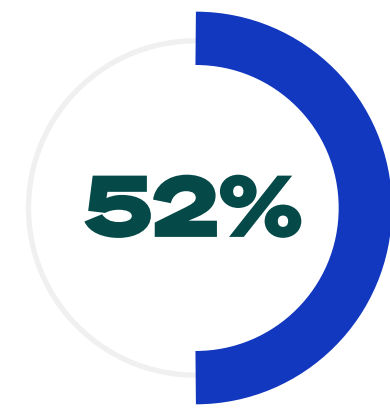

52% of retailers are investing in tools that enable their store staff to sell virtually

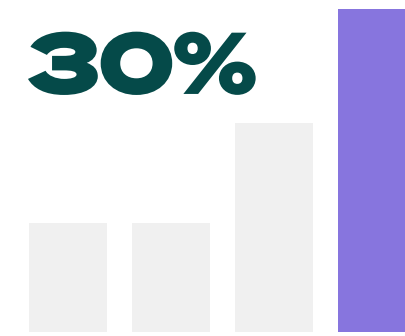

30% of retailers are offering appointment shopping to improve the in-store experience

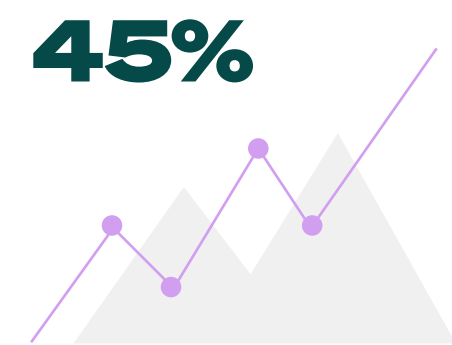

45% of brands plan to invest in enabling asynchronous chat experiences

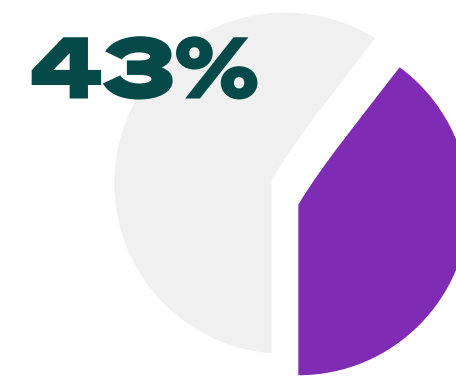

43% of consumers say they're likely to use live chat in the next year

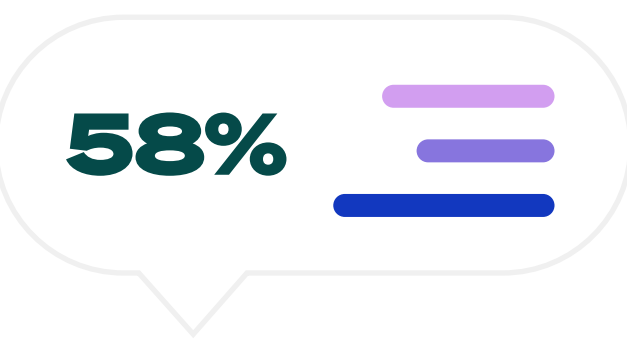

58% of consumers say the ability to reach customer service on their preferred channel influences their decision to purchase

Sourced from Shopify eCommerce Market Credibility Study, 2021

But [customer satisfaction and retention](#) require employee happiness and retention, something that's currently a top challenge in the retail industry. Employees at major retailers¹⁰⁹ have been striking, quitting, and making their unhappiness with the industry known. In the United States, job openings have hit record highs,¹¹⁰ and in the United Kingdom, employers are facing the worst shortage of job candidates on record.¹¹¹

Retailers are feeling these staffing challenges to different degrees, and for different reasons, depending on location. But one thing is true across the board: Brands need to figure out how to overcome staffing challenges if they want to succeed in an increasingly crowded retail market.



A children's wear retailer I spoke to pivoted from in-store events to virtual shopping events via zoom during COVID. Suddenly they were having one member of staff walking around the store selling products to two to 300 people per call every week, instead of just a few in person. Retailers who thought innovatively and pivoted thrived over the last period.

Kyle Monk
Director of Insight, British Retail Consortium

If retailers don't reimagine the store staff role, finding and retaining employees will be difficult

The future of the store is in the hands of its employees. That's why 40% of brands¹¹² are striving to improve employee acquisition and retention.

And although stores have begun to reopen, retailers will continue to struggle with the fallout from pandemic-induced layoffs. Forty-nine percent of brands¹¹³ say hiring and retaining employees will likely be a top challenge in the next year.

If retailers want to win back store staff, they must improve their role by rethinking job descriptions as well as pay.¹¹⁴

Once employees are hired, retailers will face the challenge of training them in technologies that power the experiences customers crave. That's why 40% of retailers¹¹⁵ plan to invest in training store staff to interact with customers using technology to improve the in-store experience. This includes [virtual selling apps](#), live chat, and using software to manage [click-and-collect](#) order fulfillment.

“

Right now there are so many positions available, but it's hard to fill them. We need to start rethinking the traditional view of these roles and how we pay them. You can't have a great business and not have good team members. Consumers are really keen on that.

Kimberly Smith
Founder, Marjani and Board of Directors,
National Retail Federation

Happy and engaged employees lead to loyal customers

Hiring retail store staff and [training them in emerging technologies](#) will not only pandemic-proof the store employee role, but also result in a better overall customer experience.

Fifty-four percent of consumers purchased from a specific brand in the last year because they could easily reach customer service on the channel of their choice.¹¹⁶ And since 58% of consumers purchased from a specific brand due to [excellent past customer service](#),¹¹⁷ retailers that invest more in their employees will win more customers.

Providing store employees with more opportunities to grow, and more flexibility, will also increase employee happiness, engagement, and retention. This in turn leads to better customer retention.

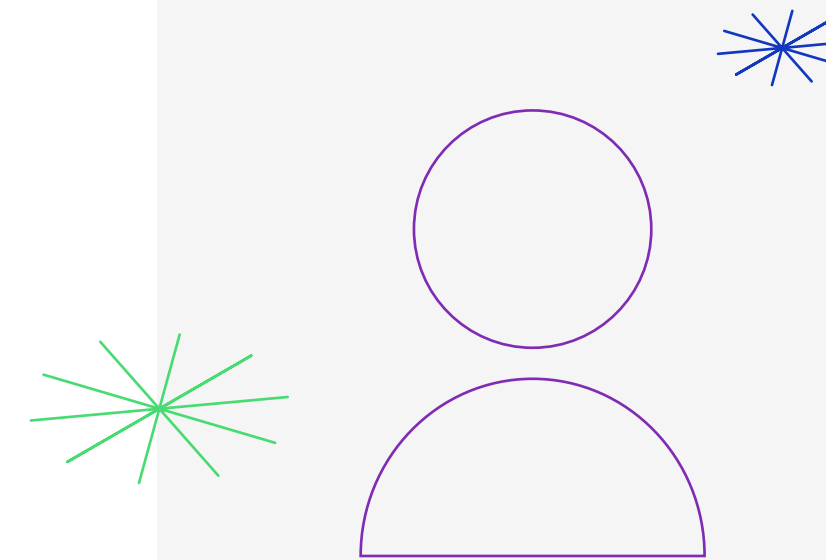

58%

of consumers purchase from brands who they've experienced excellent past customer service with

Shopify eCommerce Market Credibility Study, 2021

RECOMMENDATIONS

How to improve the employee experience and meet customer expectations

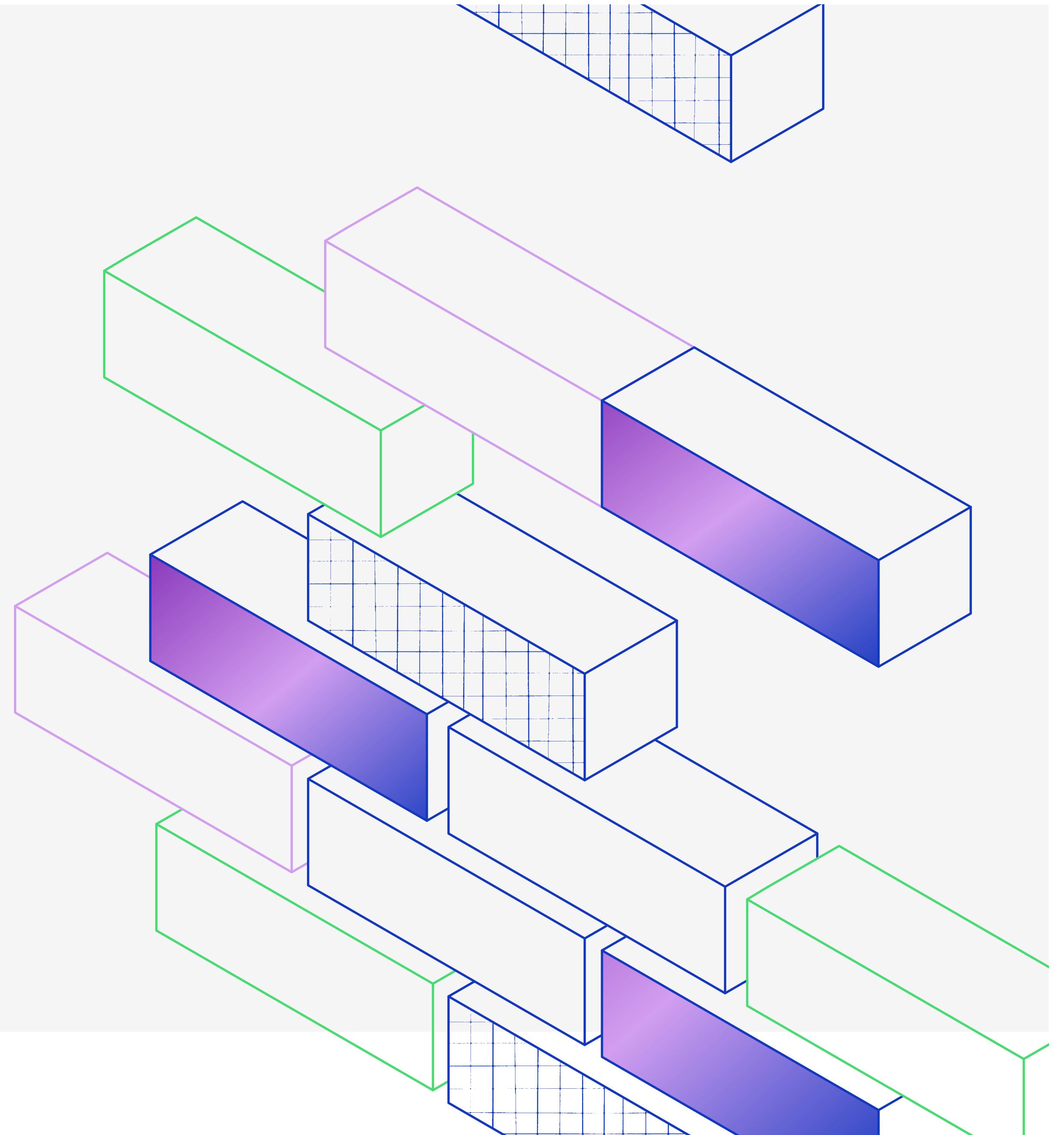

RECOMMENDATION 1

Create more specialized roles and increase compensation to match



One likely explanation for staffing shortages in the retail industry is that store employees are quitting due to burnout. Jobs that used to include folding and organizing merchandise, greeting customers at the door, pulling inventory from the stockroom, and customer checkout, now also include making sure customers are keeping a safe distance in store, cleaning surfaces routinely, managing in-person or virtual appointments, responding to live chat, and coordinating curbside pickup orders.

Store staff are demanding more benefits, flexibility, and higher pay in light of those increased responsibilities, but brands should also consider offering more specialized roles. Increased specialization not only prevents your staff from feeling spread too thin, but keeps these roles from feeling mundane, which can lead to employee churn. Consider hiring virtual shopping specialists, or staff that specialize in appointment shopping—or train high-performing employees in new technologies, to keep them learning and engaged.

“Look at your employees in a different way, not just as store staff, because that mundanity gets to everyone. Use technology to empower your store employees, as opposed to replacing them. In independent retail, you still need that touchpoint to add a human element even during virtual interactions.”

Hemant Chavan
Founder, Brik + Klik

RECOMMENDATION 2

Make sure you're providing a healthy work environment for employees



Employees stay with good teams and good managers. Creating a healthy work culture that treats employees with respect, offers flexibility, and recognizes employees for good work should be the foundation for any employee retention strategy.

One way to make sure you're maintaining a healthy work environment is to schedule weekly one-on-one meetings with store staff to check in, give and receive feedback, share praise and recognition for their work, and discuss growth plans for your employees. Whether they want to learn new technologies like virtual selling and live chat, or prefer to manage the sales floor, you can create an engaging and positive work environment that they're excited to be a part of.

MERCHANT SPOTLIGHT

How UNTUCKit unlocked employee-led growth

UNTUCKit's mission is to help every customer find the perfect fit, so it's no surprise that their store staff offer a high-touch experience to customers, complete with style recommendations and fit expertise. Even when the pandemic hit, they were able to continue offering this high-touch customer service while stores were closed through their [partnership with Hero](#), a virtual shopping platform.

Virtual shopping is not only effective, with 88% of customers¹¹⁸ purchasing within 24 hours of chatting, but it has helped pandemic-proof the store staff role.



Sometimes finding that perfect fit requires a little extra assistance, which is where our store associates are so helpful. We're excited to be able to make their expertise available to our online shoppers.

Chris Riccobono
Founder and Executive Chairman, UNTUCKit

MERCHANT SPOTLIGHT

According to Kaitlin Gottlieb, director of omnichannel sales and clienteling at UNTUCKit, although they implemented virtual shopping because their stores were closing as a result of the pandemic, virtual shopping is here to stay.

She believes this is part of a larger trend: the evolution of the retail employee role. Customers expect store staff to know things like their preferences, shopping history, and even the status of shipped orders. In response, UNTUCKit equips their store staff with omnichannel customer data, which empowers them to offer more personalized shopping experiences, and as a result, a better customer experience.

“We’re seeing good momentum with it. It’s about how to build a relationship based on where the customer wants to shop—they can help you digitally or in the store—and that’s what’s keeping customers engaged.”

Kaitlin Gottlieb

Director of Omnichannel Sales and Clienteling, UNTUCKit

Christy Farr, senior director of stores at UNTUCKit, adds that this evolution requires a change in how they recruit and pay their store staff.

“It’s no secret that it’s been challenging to hire and retain talent in retail. We’ve adapted our approach in recruiting. Our experience has shifted to a dynamic omni approach, so our employees have to be comfortable navigating that. We’ve also adapted our bonus pay to reflect associates’ omni performance so the employee gets credit for the sale on any platform.”

Christy Farr

Senior Director of Stores, UNTUCKit

Over the past decade, UNTUCKit has grown to 80 locations, due in part to how they approach employee engagement. Following UNTUCKit’s model will unlock employee-led growth for brands that want to succeed in 2022 and beyond.

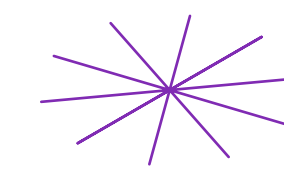
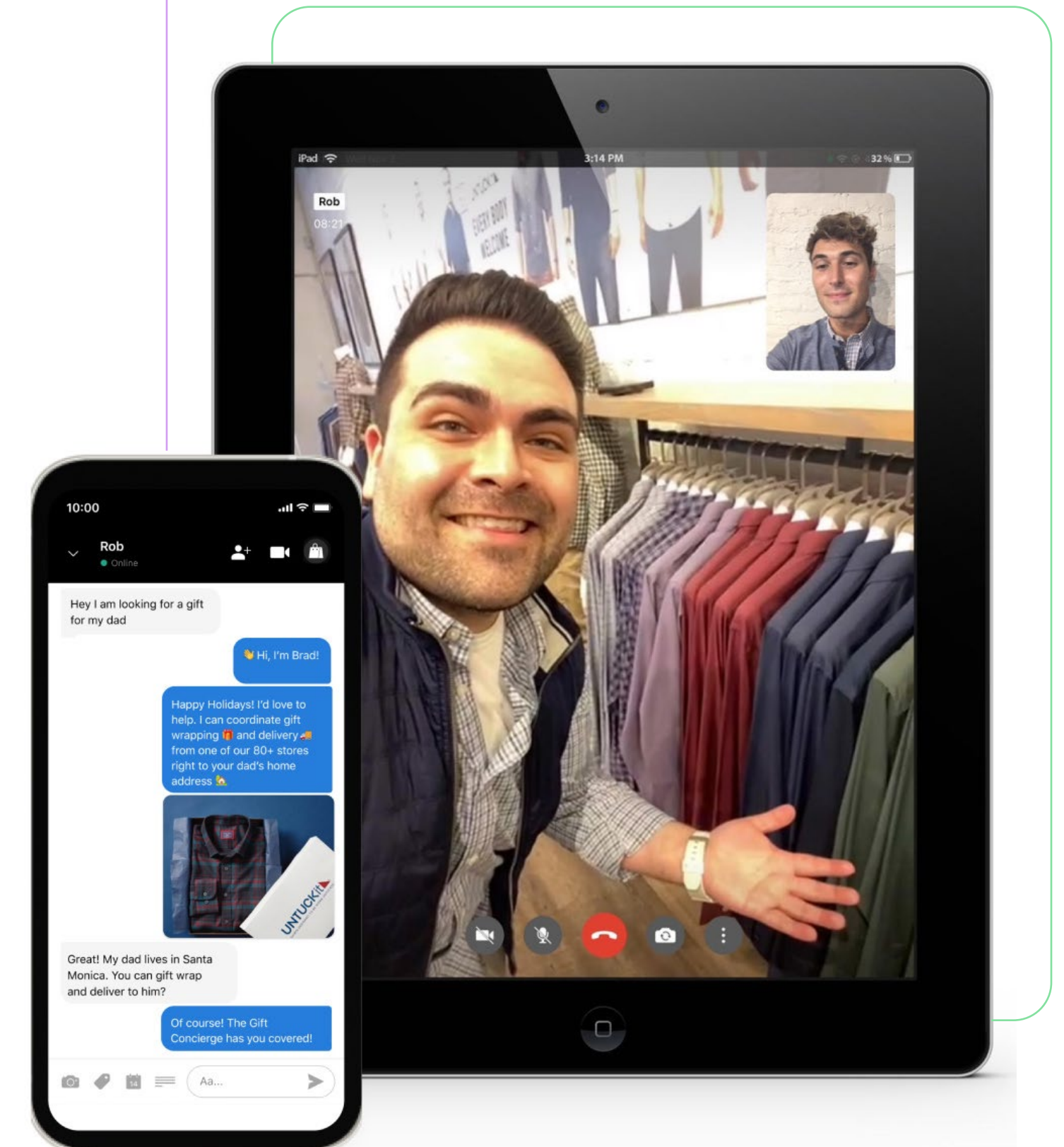

How Shopify can help

Improve customer service with virtual shopping apps

With Shopify, store staff can go beyond in-person interactions and use [virtual shopping apps](#) to serve online shoppers in real time through text and video. This technology extends in-person service to online shoppers and boost store-assisted online sales, while diversifying the role of store associates and enabling them to earn commissions for the online sales they assist.

Equip store staff with best-in-class technology

To ensure customers get the best service, equip store staff with the best tools for the job. With [Shopify POS](#), store staff can lean on customer profiles that centralize online and in-person purchase history to cater their service to the shoppers they serve better and build on the context of past interactions.

Remove redundancies and pursue sales opportunities

Try [Shopify Inbox](#) and serve online shoppers via live chat. Use automated replies to resolve common FAQs and free store staff to spend more time serving shoppers with purchasing intent. See which items shoppers have in their cart in real-time and share custom discount codes to close the sale. When shoppers are interested in out-of-stock items, send them a follow-up once you restock to close the sale.

Future of Shipping and Logistics

The shipping and logistics trends, insights, and advice you need to succeed



EXECUTIVE SUMMARY

Supply chains became the most talked about aspect of commerce in the latter half of 2021. It's unlikely that production, shipping, and fulfillment challenges will abate in the months to come.

Even if they do, vulnerabilities in the global logistics networks have been exposed, and will forever change the way merchants produce, ship, and deliver products. Consumers understand these complications, but still want goods delivered fast, free, and most importantly, on time.

Businesses who don't meet customer expectations are about to be left behind, as brands work to digitize their supply chains, improve transparency, and invest in sustainable business practices.

These challenges require new shipping and logistics strategies to thrive. That's why we've collected global, data-backed insights from hundreds of businesses and thousands of consumers to get the full picture of what's in store for 2022, as well as the strategies and products your business needs to succeed over the next year.

Welcome to the future of shipping and logistics.

TREND 1

Supply chain vulnerabilities force merchants to permanently modify their fulfillment and shipping

Merchants are rethinking where their stock is, and how to get it into the hands of customers

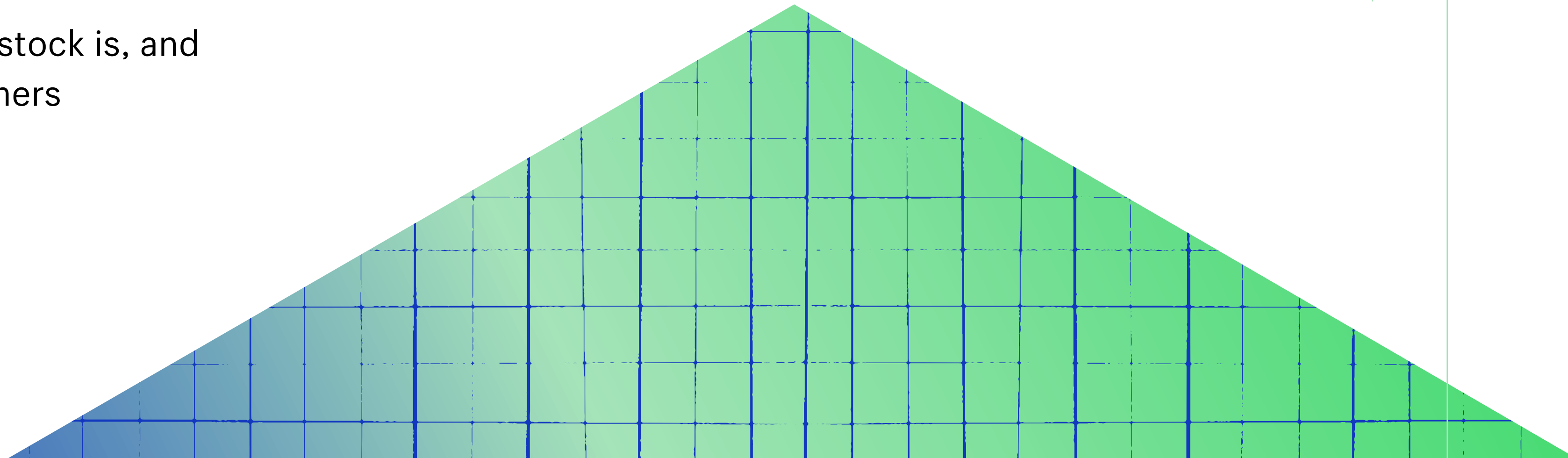

KEY TAKEAWAYS

Supply chain concerns will continue in 2022

Shipping delays, shipping costs, and manufacturing delays are the top supply chain-related concerns for businesses.

Brands are revisiting their shipping strategies

Merchants are revising their manufacturing and shipping strategies, creating opportunities to lower costs and improve customer service.

Logistics companies are building more resilient supply chains

As challenges persist over the long term, businesses will look to build resilience into their supply chains with renewed focus on digitization and decentralization.

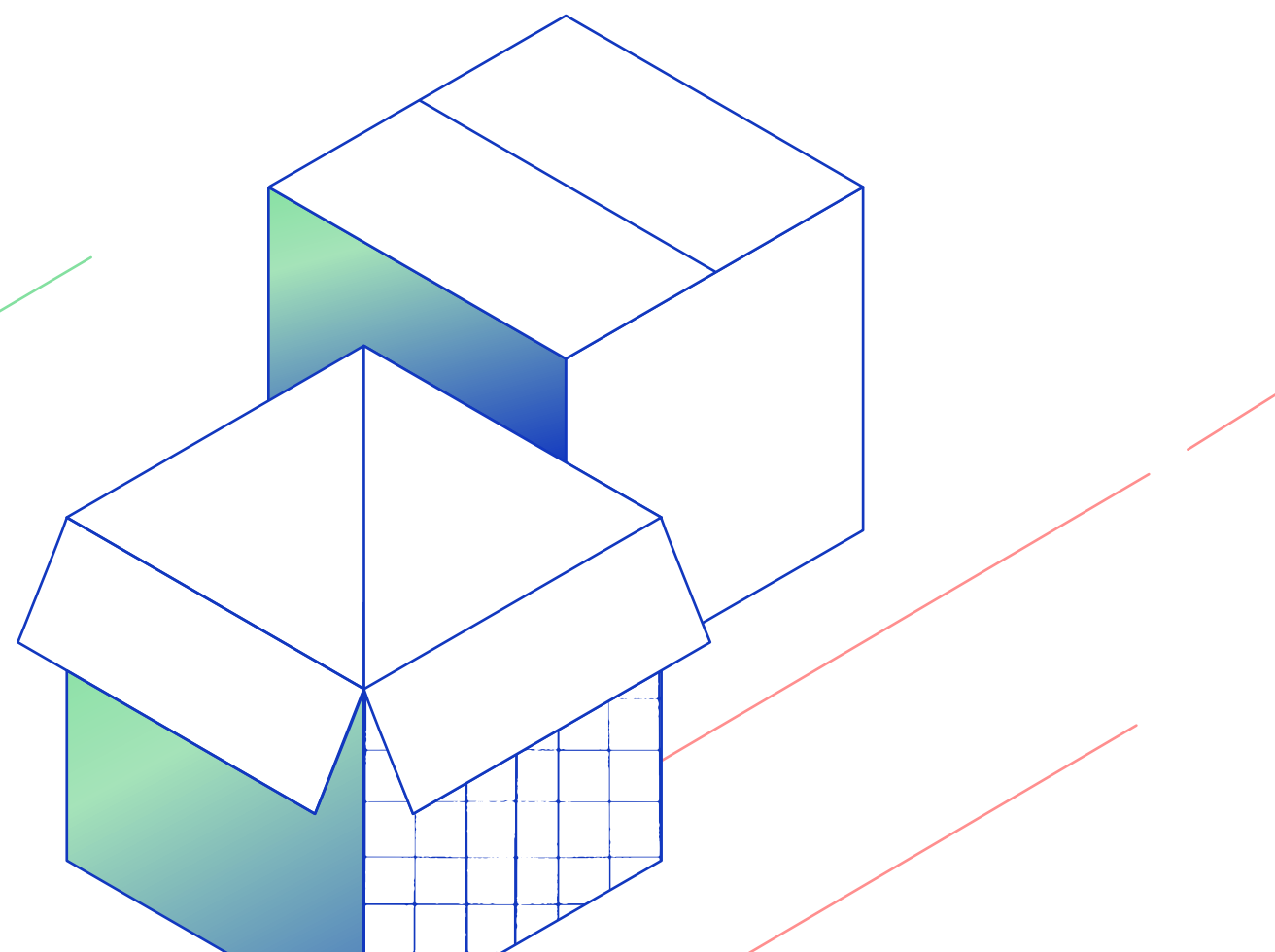

Supply chain disruptions will continue to happen with increasing frequency and severity

Years from now, we'll remember the empty shelves of 2020 as symbolic of supply and demand issues during the pandemic. But while merchants can breathe a sigh of relief that some things are once again business as usual, shipping and logistics challenges continue. According to a commissioned study conducted by Forrester Consulting on behalf of Shopify, shipping delays, shipping costs, and manufacturing delays are the top supply chain concerns brands expect to encounter in the next 12 months.¹¹⁹

Their concerns are well founded. Suppliers and shipping agents are navigating a still-changing landscape of health regulations and restrictions. In addition, ongoing global energy and raw materials shortages¹²⁰ in manufacturing hubs like China are impacting the availability of everything from milk to electronics.

At the same time, shipping container shortages have caused rates quoted by carriers and freight agents to soar. In 2019 it cost less than \$2,000 to transport goods from Asia to the United States in a 40-foot container.¹²¹ By October 2021, the same service cost around \$10,000—or up to \$25,000 if an importer paid for the luxury of ‘on-time delivery,’ a cost that’s invariably passed down to merchants.

While increasing port hours to 24/7¹²² and new air freight services¹²³ will alleviate some of the congestion, shipping internationally isn’t the only issue. Labor shortages¹²⁴ mean there may be no one to deliver goods to their next destination. And consumers aren’t the only ones engaging in panic-buying; supply chain issues have been exacerbated by ecommerce merchants¹²⁵ overstocking merchandise for sales periods.

Experts predict that systems won’t “normalize” until 2023¹²⁶ at the earliest. Even once they do, the pandemic has exposed global logistic network vulnerabilities to future political instability, natural disasters, and regulatory changes. The effects of COVID-19 were not an exception to the rule: Supply chain disruptions are happening with increasing frequency and severity. McKinsey reports that significant disruptions to manufacturing production now occur every 3.7 years¹²⁷ on average.

“There are [some experts] who think that supply chain problems are the new normal. There are other global crises afoot that are going to affect how global manufacturing happens,” supply chain reporter Rebecca Heilweil told Vox’s Explained podcast in October 2021.¹²⁸ “There’s no reason to think that this system is not going to be susceptible in the future to other problems.”

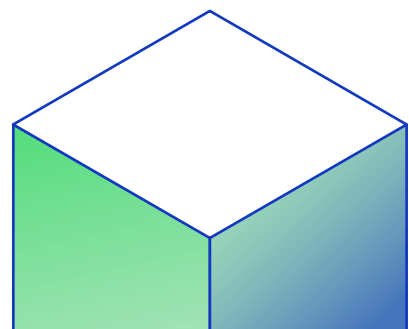
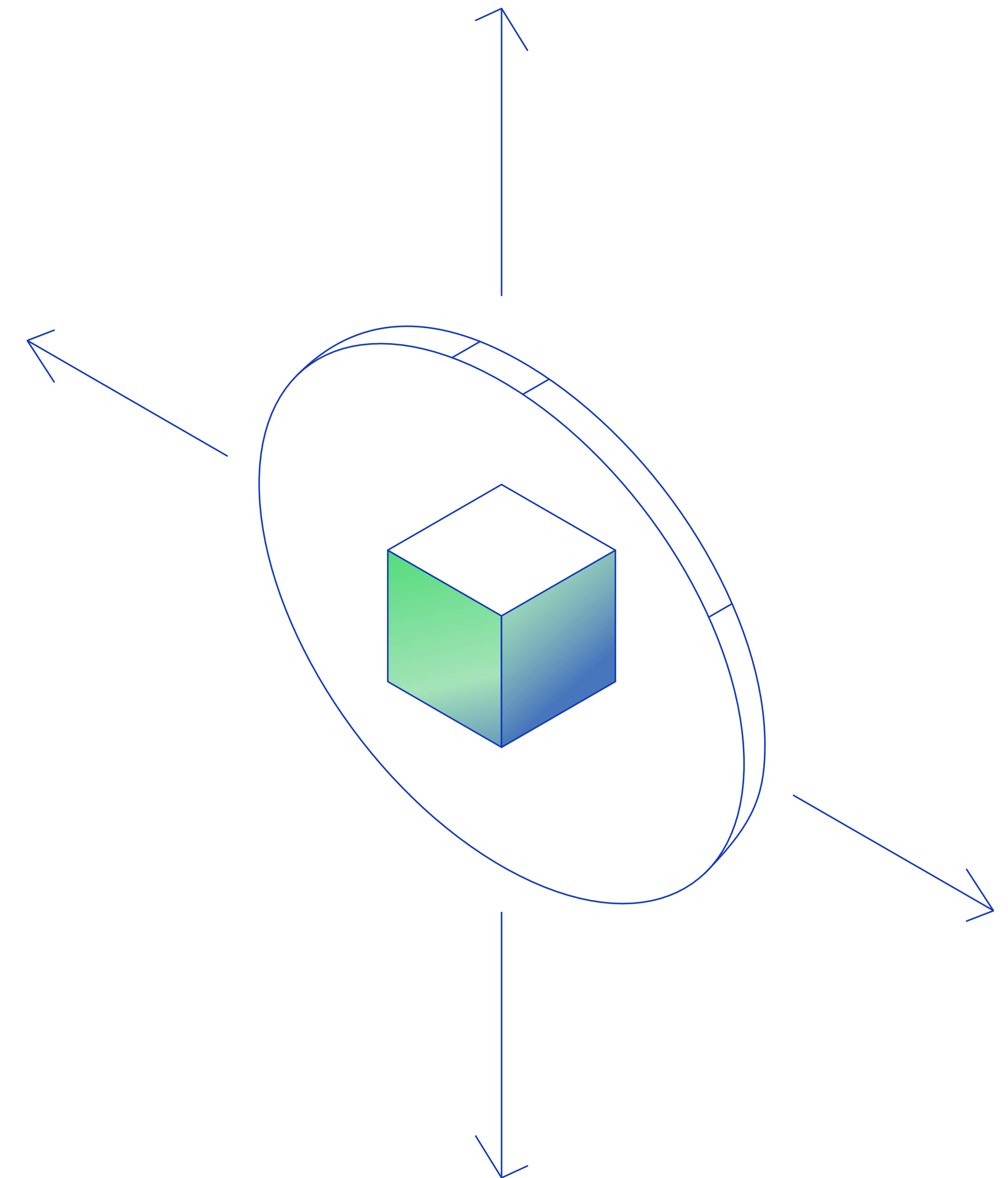

Thanks to increased competition, consumers have rising expectations of how quickly goods will be delivered

Manufacturing shortages and bottlenecks at shipping ports don't just have a real, rising cost—one that merchants must choose whether to pass on to customers. They also do damage to a brand's reputation. In an era when 60% of global consumers expect same-, next-, or two-day delivery,¹²⁹ customers aren't above turning to competitors to get their goods when products are delayed or unavailable.

Simultaneously, the pressure to provide quick delivery is only intensifying, as established brands make bold moves to meet customer demands. For example, Walmart and Home Depot chartered their own boats and containers¹³⁰ to meet the holiday sales crush—a \$40,000-per-day expense that few retailers can afford.

To keep up, merchants are being forced to make strategic changes to their supply chains—from how and where goods are produced, to where they're warehoused, to how they're shipped to customers.

“

Supply chains are not the sexiest part of retail, but it's probably the most important part that companies need to invest in. How you move your products around the globe is something brands need to quickly [address]. It's a fluid moving space.

Shaun Broughton
Managing Director of Asia Pacific, Shopify

Revisiting supply chain strategies is a chance to build resilience, reduce carbon emissions, and get products to customers faster

43%

of brands are changing shipping strategies to reduce the impact of global shipping delays

Shopify eCommerce Market Credibility Study, 2021

Merchants are already responding to this challenge, with 43%¹³¹ changing their shipping strategies to reduce the impact of global shipping delays, and 45% intending to improve their manufacturing capacity.

But re-examining strategies shouldn't just be a preventative exercise. It's an opportunity to innovate how goods are procured and shipped, benefiting customers and businesses alike.

Percentage of brands investing in supply chain management improvements

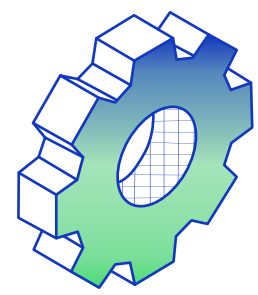

45%

Increasing manufacturing capacity

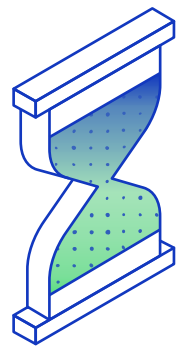

44%

Increasing speed of supply chain

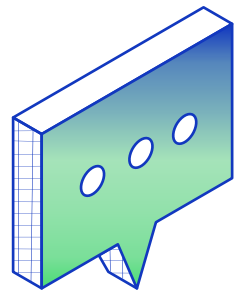

45%

Improving collaboration with supply chain partners



30%

Decreasing associated supply chain costs

Decentralizing fulfillment—including by using retail stores as warehouse centers—means parcels get to customers faster, often at a lower cost. Our research indicates that 41% of merchants¹³² plan to invest further in buy online, pick up in store options, which usually encompasses curbside pickup and click and collect. This lines up with an industry prediction that the sector will sustain double-digit growth¹³³ through 2024. For merchants with and without physical locations, smart and multi-brand parcel lockers are becoming increasingly popular, with the market expected to reach \$1.6 million by 2028.¹³⁴

“We’ve seen brands opening up distribution centers in alternative countries to help with last-mile delivery and to reduce the travel between manufacturer and doorstep.”

Leon Hughes
Associate Partner, Piper Private Equity

Data will be key in making these changes. Whereas supply chain management was once based on past years’ sales trends, merchants now have technology at their fingertips to better forecast their inventory needs. According to McKinsey, early adopters of artificial intelligence-enabled supply chain management can improve logistics costs by 15%,¹³⁵ inventory levels by 35%,¹³⁶ and service levels by 65%,¹³⁷ compared with slower moving competitors. The growing use of cloud-based software, which allows supply chain partners to share real-time data, is also hugely beneficial.

Likewise, data-driven optimized routing—a strategy 31% of merchants¹³⁸ plan to employ in the next 12 months—can also reduce carbon emissions. According to a study released in 2021 by MIT, this strategy can save 50% of transport-related greenhouse gas emissions,¹³⁹ and reduce the overall footprint per package by an average of 10%.

Sourced from Shopify eCommerce Market Credibility Study, 2021

RECOMMENDATIONS

How to build a resilient shipping and fulfillment strategy

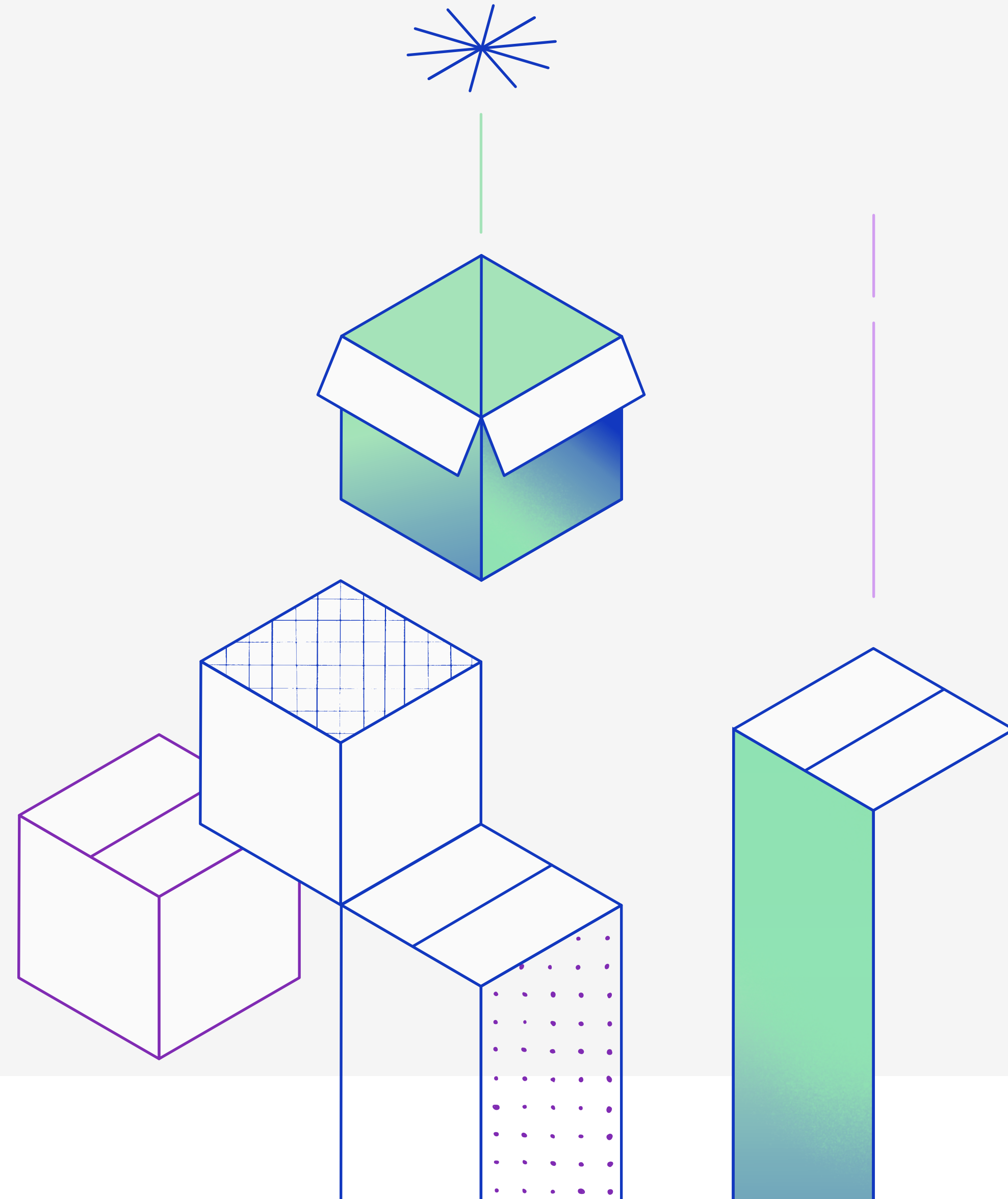

RECOMMENDATION 1

Digitize your supply chain to improve visibility and responsiveness



Use data and technology to make smarter inventory management decisions

While shorter supply chains are a medium- to long-term goal for some companies,¹⁴⁰ using data and technology to make smarter inventory management decisions should be your priority in the immediate future.

In the coming year, 38% of the merchants¹⁴¹ we surveyed plan to integrate technology to help their company anticipate disruptions and demand, while 33%¹⁴² plan to digitize legacy manual processes within the supply chain. For many Shopify merchants, actions to digitize supply chains are picking up pace: Between January 1, 2021 and September 30, 2021, app installs for warehouse management grew by 198%, while app installs for order and shipping reporting grew by 53% compared to the same period in 2020.¹⁴³

RECOMMENDATION 1



Use cloud-based solutions

Digitizing supply chains can range from the affordable option of scanning apps or inventory management software to the more advanced option of relying on machine learning, internet of things, and AI-based solutions to do everything from load pooling to dynamic rerouting.

Whatever solution you choose should be cloud based. According to Reuters Events,¹⁴⁴ it is “the single most important tool supply chains need to future-proof their operations.” Cloud-based supply chain management software makes it possible to identify problems, make decisions, and communicate with partners along every node of your supply chain—all in real time.

This results in what Supply Chain Game Changer CEO Mike Mortson calls “lead time–agnostic supply chains.”¹⁴⁵

“When you can respond quickly enough and with sufficient agility, then it no longer makes sense to talk about lead times at all.” This same logic applies to forecasting and preventing overstock and understock. Ultimately, it might even help merchants achieve “zero inventory,”¹⁴⁶ where they hold little to no inventory and instead make products to order, eliminating the risk (and cost) of holding inventory that might not sell.

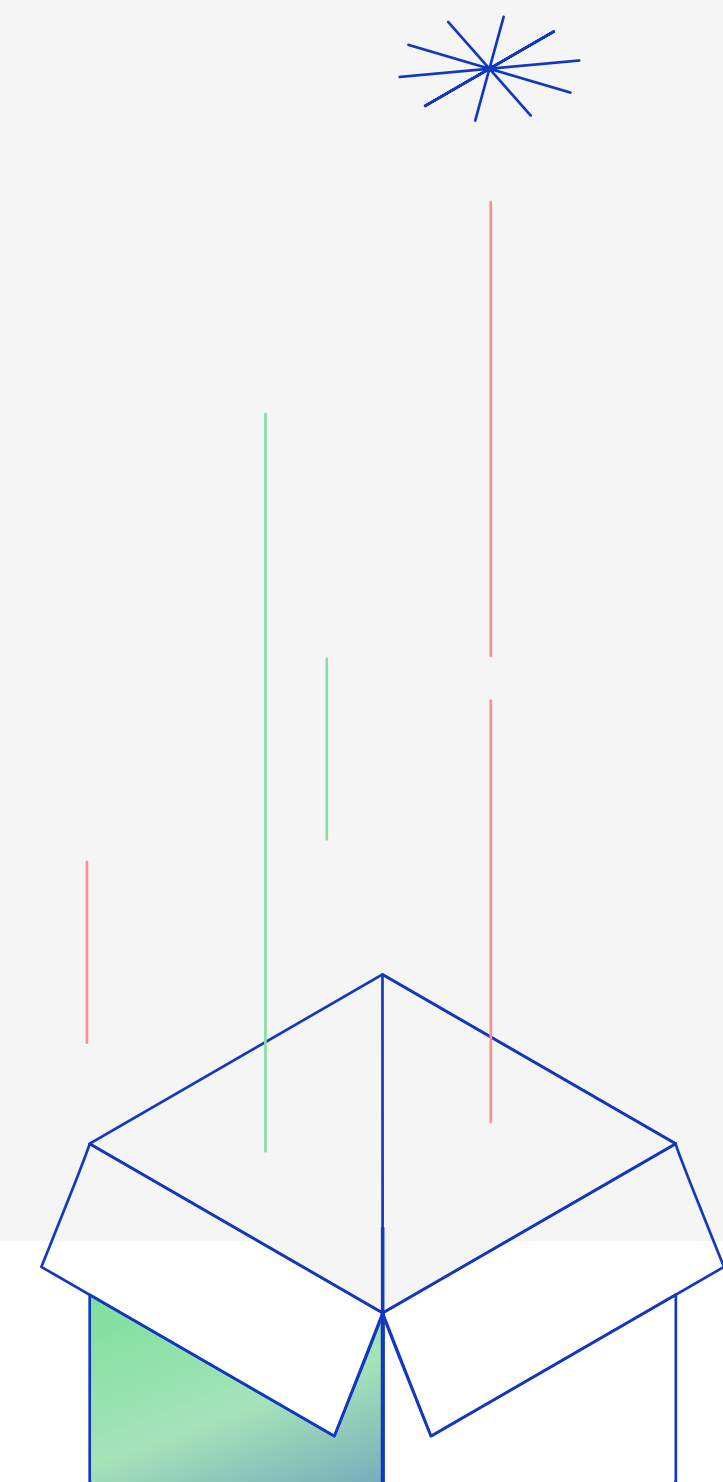

RECOMMENDATION 2

Use data to optimize your fulfillment strategy



Audit your data and processes

Conducting a thorough analysis of your shipping and inventory data, alongside a supply chain vulnerability audit, will help you determine situations that could affect your sales, identify backup suppliers and routes, and gain greater understanding of your customers' locations and delivery preferences.



Redistribute inventory closer to your customers

Redistributing your inventory to locations closer to your customers reduces costs by keeping merchandise within shipping zones—allowing you to provide same-day or two-day shipping without incurring extra costs—and increases resilience against regional supply chain snags.

If you're a retail business, consider turning brick-and-mortar stores into mini-fulfillment centers. The conversion of just one retail store into a mini-fulfillment center has the potential to reduce last-mile costs by more than 60%.¹⁴⁷ These hybrid retail spaces are also an opportunity to offer curbside pickup and click-and-collect options.

"We're thinking about things like making our stores mini-distribution centers, where we have the room to help support our distribution center. Multi-warehousing is something brands will look into so they're able to be closer to customers."

[Ariel Kaye](#)

[Founder and CEO, Parachute](#)

If your business doesn't have physical stores, consider opening a micro-fulfillment center in an urban location. It's a more viable option than ever before, thanks to pandemic closures, high vacancy rates, and relatively affordable commercial spaces. In fact, it's expected to become a billion-dollar market in 2022¹⁴⁸ as brands seek to shrink the distance between products and consumers—either with a larger number of small inventory centers, or fewer, larger spaces shared between multiple brands.

RECOMMENDATION 3

Consider outsourcing your shipping and fulfillment to a 3PL

✓ Tap into 3PL infrastructure

Once perceived as a solution only for enterprise-sized brands, third-party logistics providers (3PL) are now key for merchants of any size with intentions to scale. The 3PL market is expected to expand at a compound annual growth rate of 8.5%,¹⁴⁹ with the fastest growth taking place in Asia Pacific. Globally, 37% of merchants¹⁵⁰ plan to hire or change 3PL or fulfillment providers in the coming year.

With pre-negotiated contracts and a network of fulfillment centers spread across the country and around the world, using a 3PL can offload the time and stress of managing shipping logistics in house, while keeping costs down. 3PLs with their own delivery vehicles are also investing in smaller trucks and vans,¹⁵¹ which can support shorter distances and more frequent deliveries.

✓ Test new markets

Working with a 3PL can also create opportunities to test new markets without the need to invest in infrastructure or blindly navigate the legalities of overseas markets.

✓ Insulate your business from additional risks and charges

Working with a 3PL might not eliminate shipping surcharges, but it will insulate you from them and diversify your risk because 3PLs typically have relationships with multiple carriers.

Just remember that logistics providers aren't immune to the supply chain challenges plaguing the market, a point underscored when American Eagle acquired fulfillment operator Quiet Logistics in November 2021¹⁵² to ensure its orders were prioritized. Be sure to come equipped with the right questions¹⁵³ and expectations during the evaluation process.

MERCHANT SPOTLIGHT

How Doe Lashes built a resilient inventory and fulfillment strategy

In under five years, California-based Doe Lashes has grown from a \$500 launch to a multi-million-dollar business.

Sales tripled in 2020 alone. This, in part, was due to a unique moment of opportunity for Doe Lashes and other beauty brands. When the pandemic made masks the norm, eyes were the only visible part of the face, and sales of eyeliner, mascara, and fake lashes all soared.

A large graphic showing the number '80%' in a light green color, with the percentage sign in a blue color.

of Doe Lashes company operations are now automated

Growth during such a period of disruption hasn't been plain sailing. Doe Lashes faced challenges including stockouts, shipping delays, and cash flow. "A lot of our products are bundled together," says Jason Wong, CEO and founder of Doe Lashes. "This means if we're missing one item, it actually means stocking up for two or three others, and that can be scary."

The team minimized this fear by investing resources into their own supply chain logistics. Automation has been key to their success. The company has built a back-end system with a series of automated alerts related to demand forecasting, giving them accurate information on when to place orders and when products are going out of stock.

“

We look at where our customers are placing their orders from. The way we respond is to place our inventory near those cities to reduce the overall miles traveled by those packages.

Jason Wong
CEO and Founder, Doe Lashes



This information means that Doe Lashes can reorder a lot sooner, with the confidence to order quantities that avoid cash flow issues related to over- or under-ordering. Operations at the company are currently 80% automated, freeing up time for the six-person team to focus on creative and strategic areas of the business instead.

Distributed warehouses have also helped the team get products into the hands of customers as quickly as possible. Doe Lashes uses customer data insights to determine where products should be located to ensure the fast delivery times that consumers expect.

As a result, orders arrive faster and with fewer carbon emissions. The strategy makes good financial sense for Doe Lashes and increases customer satisfaction. Wong continues, “We’re now stocking inventory outside of the country for our international customers, just to reach them faster. We have a warehouse in China and that helps us reach Australia and the whole Southeast Asia region.”

With automated processes and a tried-and-tested formula to minimize the distance between products and customers, Doe Lashes is building a business that is resilient against the supply chain disruptions of today and tomorrow.



How Shopify can help

Automate your fulfillment tasks

Use Shopify Flow to automate your inventory and fulfillment tasks so you can get orders out the door more quickly. You can also use Shopify Flow to automate low-stock notifications, organize variants more effectively, and add tags to orders.

Automate day-to-day tasks and workflows with Shopify Flow →

Manage all your orders in one place

From order received to order delivered, you can manage all your orders across multiple sales channels in one place with Shopify. This includes managing and prioritizing orders, adding notes and tags, editing orders, creating and purchasing shipping labels, and managing returns.

Manage orders and delivery in one place with Shopify order management →

Bring inventory closer to your customers

Use Shopify to manage, monitor, and move inventory across any location to bring your products closer to customers. Sales and inventory reports make it easy to forecast sales demand, while transfers simplify the process of moving inventory between locations.

Alternatively, outsource inventory management and fulfillment. With Shopify Fulfillment Network, we can pick, pack and ship orders for you, so you can spend more time managing your business. Or, use one of Shopify's premium third-party logistics (3PL) partners with seamless integration into your Shopify store.

Get your orders out the door more quickly and affordably with Shopify Shipping →

TREND 2

Social and environmental impact will define the next era of shipping and logistics

Consumers are demanding socially conscious and environmentally sustainable businesses, with profit increasingly dependent on purpose

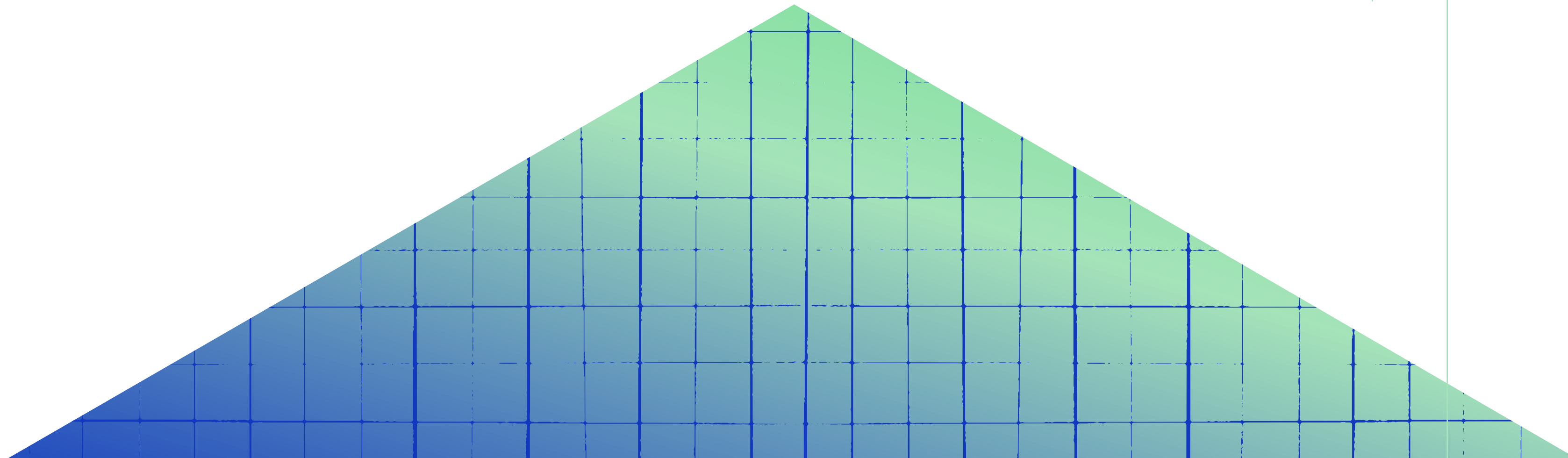

KEY TAKEAWAYS

Consumers are seeking sustainably operated businesses

Consumer intentionality has shifted to action, as more people purchase products from sustainably operated businesses.

Brands are implementing more sustainable practices

Merchants focus on improving their sustainability, including both their environmental and social impacts.

Sustainability is improving customer and employee retention

Businesses that invest in sustainability through their supply chain will reap returns in customer and employee retention.

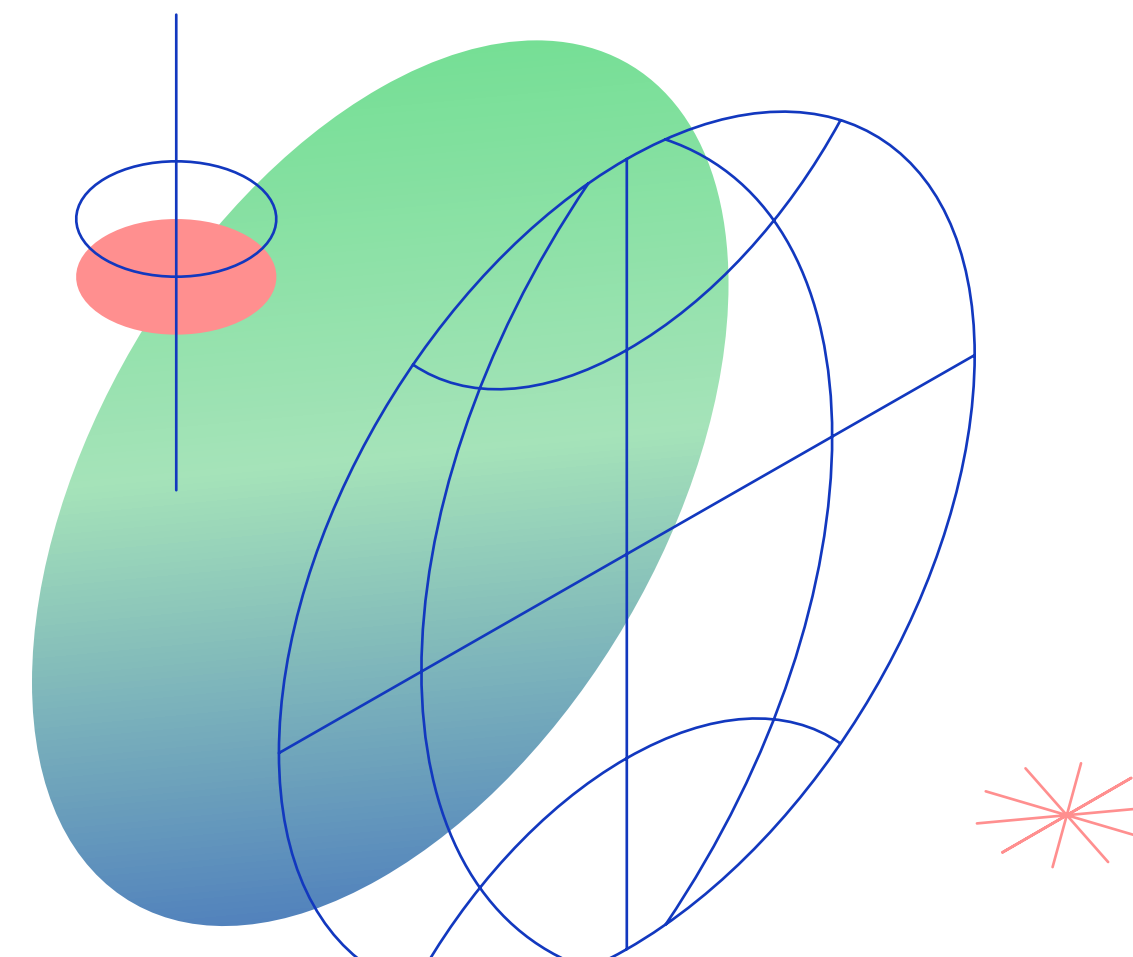

Customers are starting to put their money behind their beliefs

53%

of companies are making improved sustainability one of their top priorities for 2022

Shopify eCommerce Market Credibility Study, 2021

For years customers have indicated their willingness to buy from purpose-driven brands. In the last six years, there's been a 71% increase in online searches globally¹⁵⁴ for "sustainable goods," especially in high-income countries like the United Kingdom, the United States, and Canada.

Actions haven't necessarily matched intentions—until now. In the past year, 44% of customers¹⁵⁵ chose to buy from brands that have a clear commitment to sustainability, while 41% chose to buy from brands that have a clear commitment to social causes. Overall, the consumers we surveyed want brands to have "actions that match their values."

Percentage of consumers who are more likely to buy from a brand with a clear commitment to sustainability

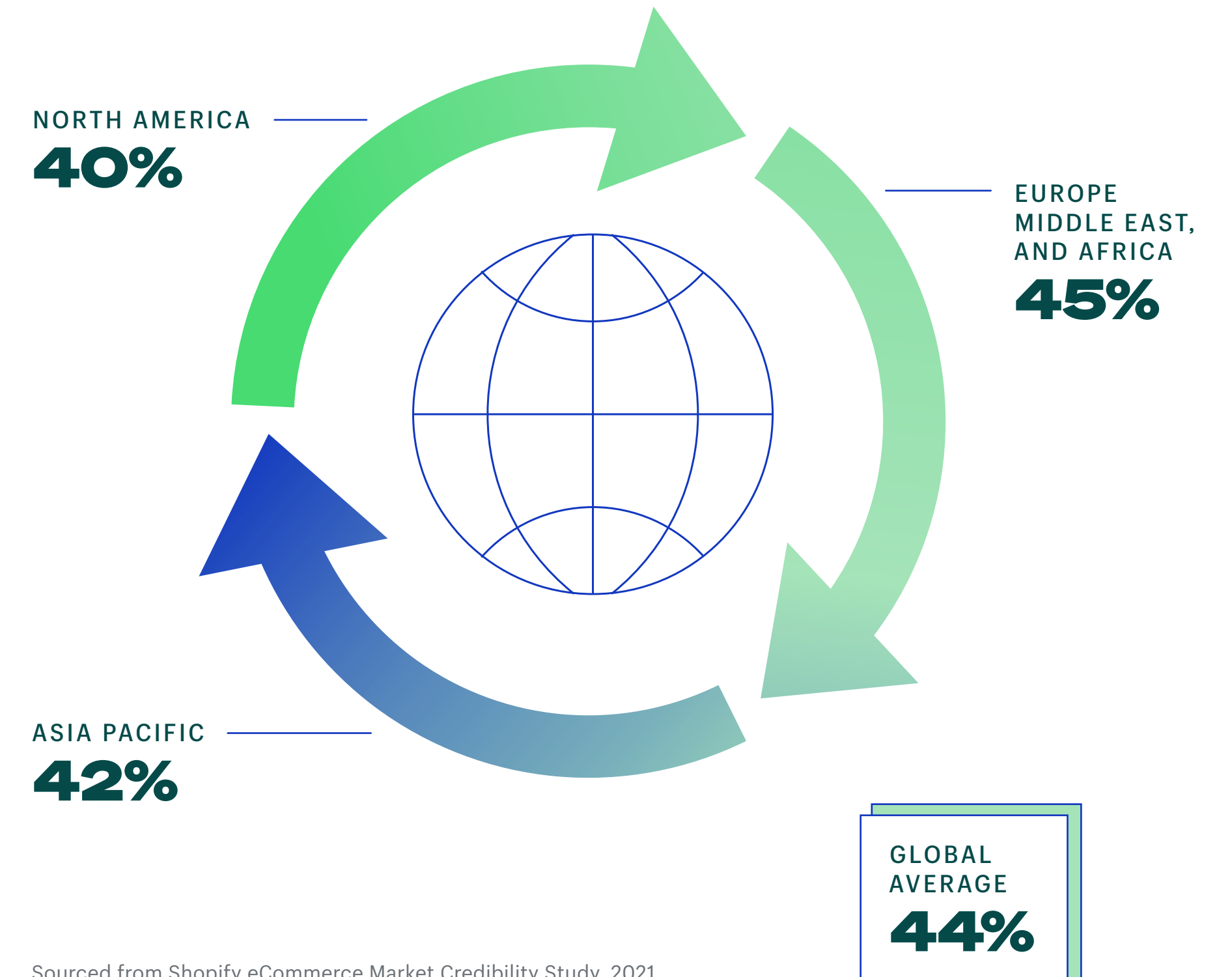

Sourced from Shopify eCommerce Market Credibility Study, 2021

Consumers are no longer just virtue signaling. They're finally putting money behind their beliefs, and brands are responding: 53% percent of companies¹⁵⁶ are making improved sustainability one of their top priorities for 2022, and 39% are improving efficiency in manufacturing processes.

But merchants aren't just focused on reducing their carbon footprint; they're also examining the social impacts of doing business, like the fair treatment of factory and fulfillment workers. A quarter of merchants¹⁵⁷ say one of their biggest supply chain-related concerns is ensuring manufacturing partners employ ethical and fair labor practices. More than one-third¹⁵⁸ report taking a more holistic approach to sustainability in the year ahead, and distancing themselves from partners that are unwilling to meet their sustainability standards.

Top sustainability initiatives brands are investing in over the next year

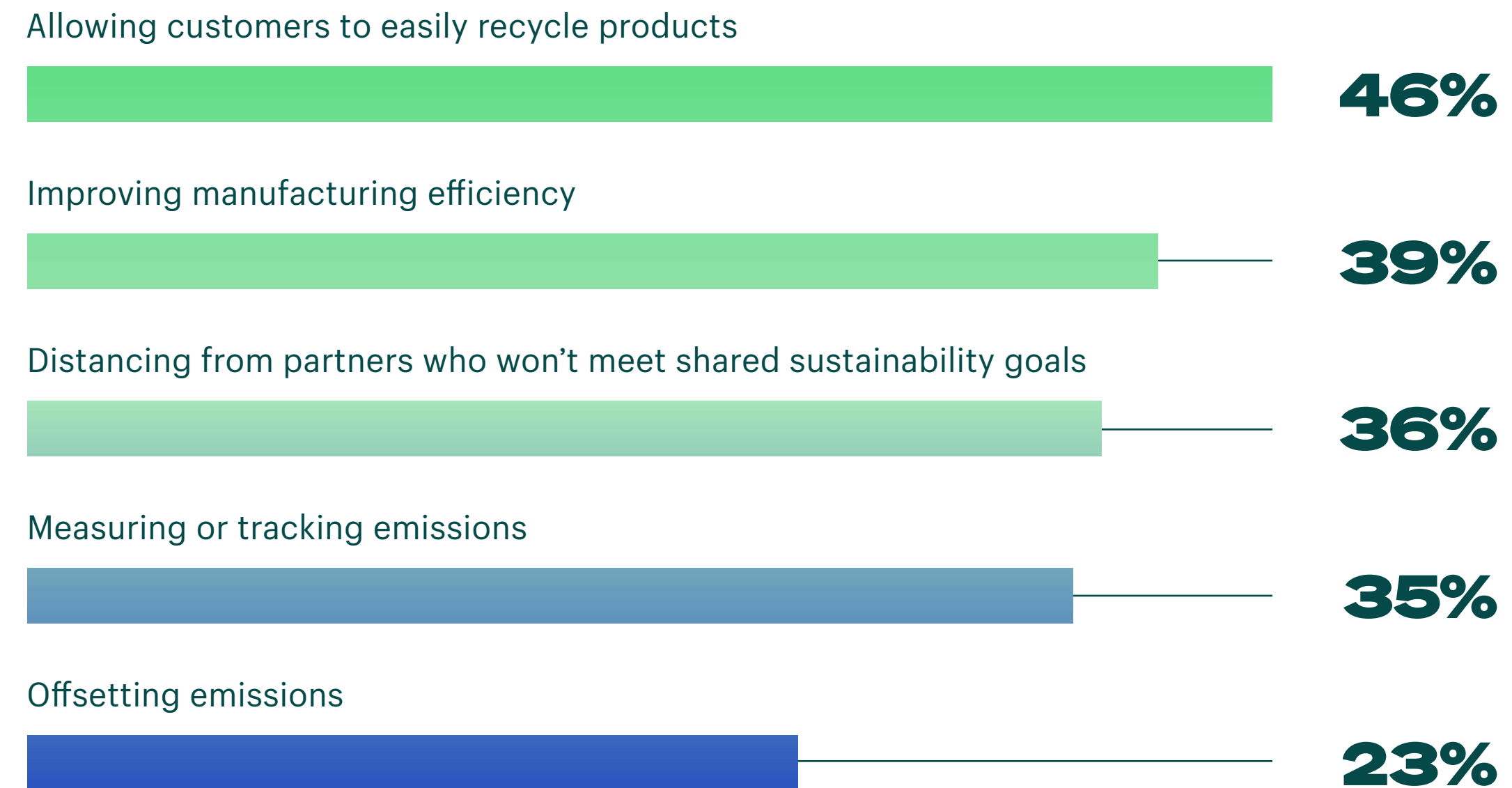

Sourced from Shopify eCommerce Market Credibility Study, 2021

Sustainability becomes an imperative as regulators move in, and customers demand transparency

There are many challenges to implementing sustainable practices, not least that they typically require a higher upfront investment. This explains why some businesses position themselves as “sustainable,” without adopting truly impactful practices.

Thanks to increasing media coverage of human rights issues and the climate crisis, sustainability has to become more than just a positioning exercise. Journalists and consumers alike have better resources than ever before to assess and report on how goods are made, with third-party organizations and databases like the Fashion Transparency Index¹⁵⁹ and the Impact Index¹⁶⁰ ranking brands and retailers on their social and environmental policies and actual impact.

In the future, the ongoing development of blockchain technology¹⁶¹ will give consumers even more avenues to trace the origins of their goods with greater accuracy. Forward-thinking brands are getting ahead of the conversation. With 41%¹⁶² planning to be more transparent about their social impact’s vision, goals, and progress.

But let’s be clear. Shifting to environmentally and socially sustainable supply chains will soon no longer be a choice—it will be a requirement. In the coming years, retail businesses will increasingly be held accountable for their sustainability practices by governments, shareholders, and customers. We have already seen an evolution in supply chain legislation, with Australia¹⁶³ and the United Kingdom¹⁶⁴ developing modern slavery acts, and California enacting the Transparency in Supply Chains Act.¹⁶⁵

It’s not just the [B Corp](#)-certified set who are making changes. Brands both small and large are adopting a “cradle-to-cradle” or “circular economy” mentality when it comes to production, distribution, and the end life (or continued life) of goods. Swedish children’s wear brand Polarn O Pyret allows buyers to return outgrown outerwear in exchange for a voucher.¹⁶⁶ It’s then available for secondhand sale. And activewear brands Lululemon and Sweaty Betty have similar programs.

Going forward, merchants will need to comply with more stringent human rights and environmental regulations, including extended producer responsibility measures, which seek to manage and reduce consumer waste.

Focusing on sustainability will ultimately position businesses for long-term growth

Consumers say they're more likely to be loyal to brands offering clear commitments to sustainability—including the conditions under which goods were made and the environmental impact of their production. This means sustainability isn't just critical to improving global environments and working conditions. It's important to make sales, and to earn and keep trust among multiple stakeholder groups.

Sustainable practices have been proven to appeal to customers, investors, and employees. They help customers maintain more emotional relationships with brands, which has been shown to result in a 306% higher lifetime value.¹⁶⁷ With a growing number of firms committing to impact investing,¹⁶⁸ a brand's sustainability credentials might also attract new partnerships and investors.

Finally, sustainability can improve employee retention. Multiple studies show that businesses with better environmental standards and corporate responsibility typically have higher productivity and lower staff turnover. Fifty-six percent of professionals¹⁶⁹ report being more likely to stay in a company with a sound sustainability agenda.

“

We are seeing a lot more brands coming to the table where sustainability is actually foremost. They promote every aspect, even in the supply chain. It's not just the consumer pull—it's employees, as well. Many employees want to work for more ethically based companies.

Leon Hughes
Associate Partner, Piper Private
Equity

RECOMMENDATIONS

How to make your supply chain more sustainable

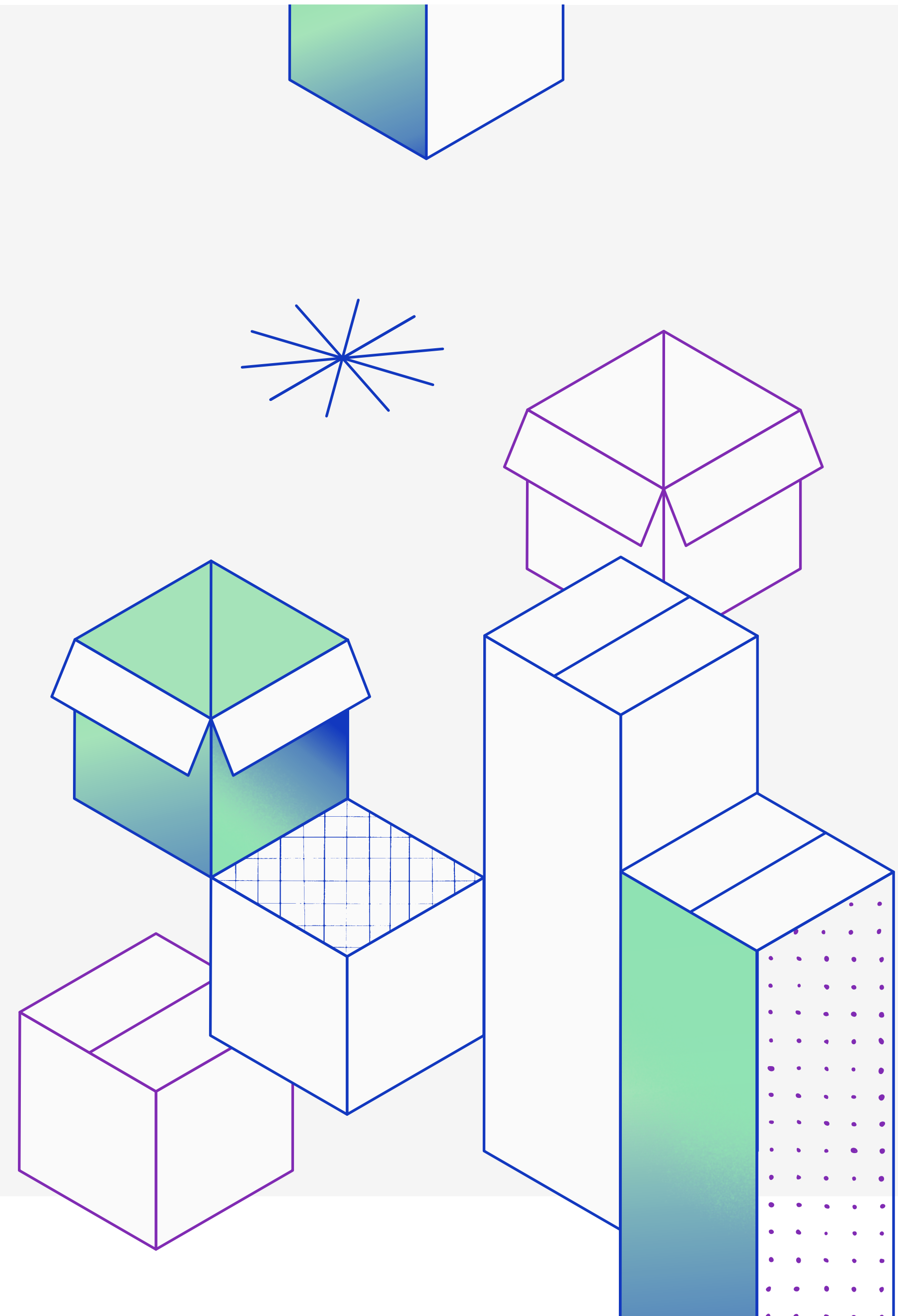

RECOMMENDATION 1

Find ways to reduce your carbon footprint



Offset carbon emissions

The World Economic Forum estimates that parcel deliveries will increase by 78%¹⁷⁰ globally by 2030, resulting in 32% more emissions. Yet 42% of consumers¹⁷¹ said that “knowing a brand is actively working on reducing their carbon footprint” is important when deciding whether to purchase a product online. One way to address your carbon footprint is through offsetting. Currently, only 23% of brands¹⁷² are offsetting emissions, but this is predicted to grow significantly¹⁷³ in the years ahead.



Revisit your last-mile delivery

One of the first places you should look to reduce your impact is in last-mile deliveries. To reduce your carbon footprint, you could join IKEA, Walmart, and UPS in electrifying your delivery fleet. According to a 2020 study conducted by the MIT Real Estate Innovation Lab, this technology can now decrease ecommerce delivery emissions by 27%,¹⁷⁴ and by considerably more as the electricity grid is decarbonized.

Newer electric vehicles have a range of 200 miles,¹⁷⁵ capable of handling 90% of all last-mile deliveries. Scooters and bicycles can also be used.



Reduce your fulfillment footprint

If you don't have your own delivery fleet, there are ways to reduce your footprint in your fulfillment processes, like decentralizing inventory centers, using parcel lockers, or working with a 3PL. Not only will your customers receive their goods faster, but building out logistics networks, including urban fulfillment centers, can reduce transportation-related emissions by 50%.¹⁷⁶

RECOMMENDATION 2

Make product packaging recyclable, compostable, or reusable

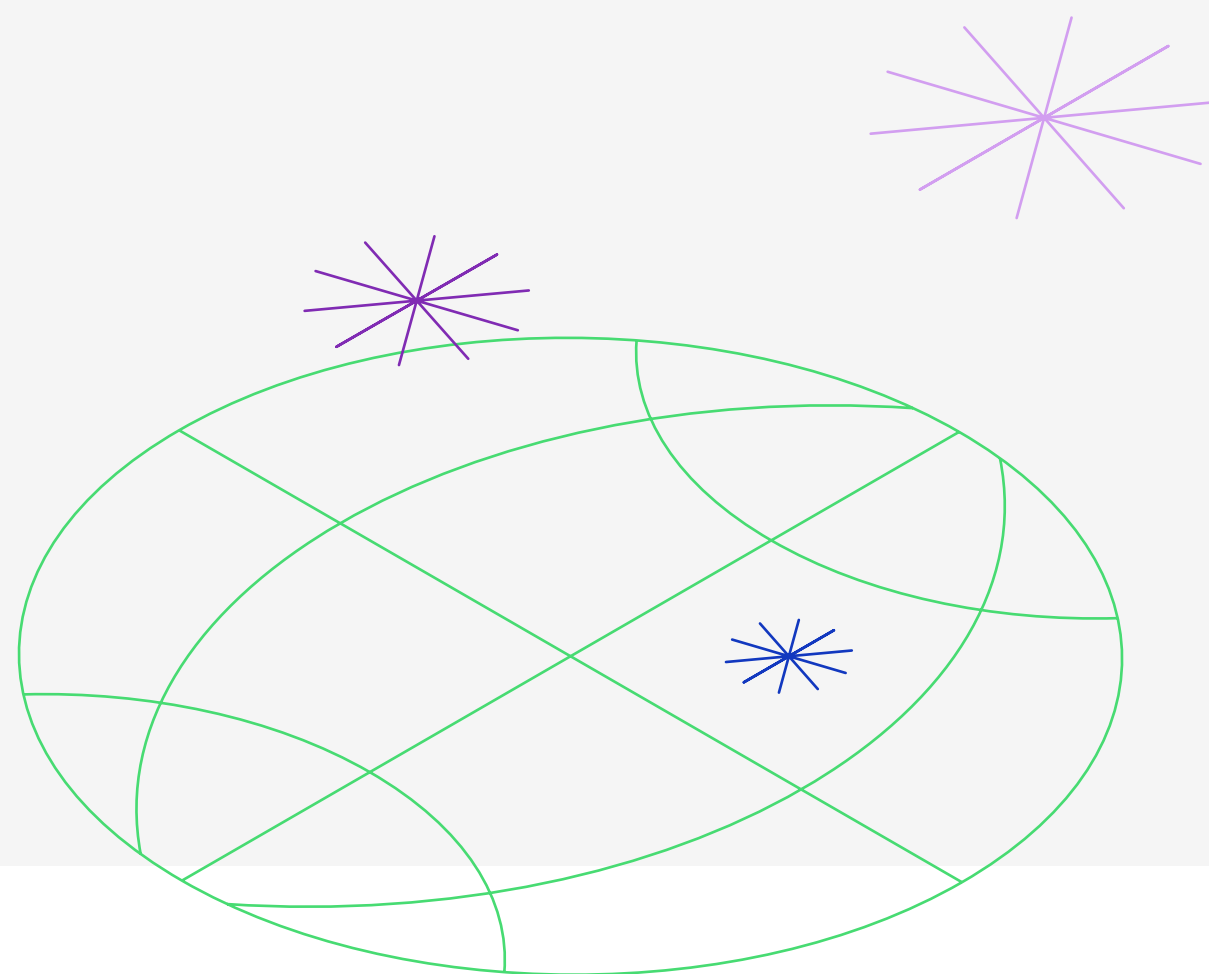

Invest in sustainable packaging to reduce impact

According to our research, 46% of customers¹⁷⁷ are more likely to purchase a product online if they're able to recycle the product packaging. This is part of the reason why 40% of brands¹⁷⁸ are highlighting more sustainable packaging as an area of investment.

The issue is bigger than consumer demand, though. Packaging is the largest source of ecommerce emissions, at six times higher¹⁷⁹ than products purchased in store.

Now is the time to re-examine how you're packing and shipping products, whether that's using compostable or recyclable mailers or looking into reusable packaging, another method of supporting the circular economy.



Work with credible partners

In Australia, [The Better Packaging Co.](#) designs a range of environmentally friendly packaging for ecommerce merchants, ranging from poly bags and garment bags made from 100% recycled ocean-bound plastic pollution to fully compostable and biodegradable mailing satchels. [EcoEnclose](#) offers similar options to merchants in the United States. Lastly, startups like [LimeLoop](#) are offering reusable vinyl packaging that can be used up to 2,000 times, saving around 1,300 trees and two million gallons of water for every 100 deliveries.



Use AI to make packaging decisions

In addition to replacing packaging with more eco-friendly alternatives, using artificial intelligence to analyze and determine the best size and type of packaging for different combinations of items can help reduce emissions. Swapping out boxes for padded mailers, for example, can reduce the weight and volume of packages in a delivery vehicle, which lowers emissions.

RECOMMENDATION 3

Hold your business accountable to sustainability goals

Revisit your internal processes and targets

Before government and regulatory change mandates it, look at your internal processes and determine targets for your business, as well as how to audit and report on them, both for your internal stakeholders and for your customers. This can include creating codes of conduct and stricter procurement policies, and performing regular audits on your suppliers' practices and operations. Most environmental and human rights violations occur within suppliers' and 3PLs' own lower tier suppliers.¹⁸⁰

Communicate progress with your customers

How you then communicate this to your customers depends on your brand. [Nike](#), for example, maps its manufacturing plants. Sustainable industry leader Patagonia shares details about vendors operations and staff on its [Footprint](#) page. Womenswear brand [Reformation's](#) mission is embedded in its tagline (and tags): "Being naked is the #1 most sustainable option. We're #2." The brand encourages customers to "geek out on our sustainable practices" online, with detailed information on everything from local manufacturing to the use of recycled clothes hangers.

Keep your sustainability and social impact messaging simple

Whatever you do, don't make it complex. Of the consumers surveyed, 41%¹⁸¹ said a significant influence on their purchasing decisions in the last year was when a brand made it "easy to understand the actions they are taking to achieve their environmental and/or social impact goals."

MERCHANT SPOTLIGHT

How A Good Company champions sustainable business practices



A Good Company is on a mission to transform commercial consumption into conscious decisions. While they’re at it, the team is also proving that it’s possible to embed sustainable practices throughout the supply chain.

For A Good Company CEO Anders Ankarlid, this means communicating the environmental impact of every product—from materials to water consumption to the source of energy used in production. The information has been a hit with website visitors.

Along with full supply chain transparency, Ankarlid sees an opportunity to help consumers make more informed, responsible choices. He notes that this will become more important because “people are going to become more cautious about what they buy and for what reasons.”

A Good Company applies this logic to its delivery and returns policy, which, Ankarlid admits, can be a “conversion killer.” He explains, “We don’t believe it’s okay that you buy one notebook and expect free shipping—that’s not sustainable for anyone. So we incentivize our customers to buy a little bit more at the same time. That way they get better bulk pricing and we can ship the order in the most sustainable way possible. A lot of what we do is to influence consumers to calm down, take a chill pill.”

A Good Company sees **20% higher** impressions on sustainability-focused web pages



Thoughtful and well-designed products are not the only reward when a customer receives their order. Just as much consideration has gone into the packaging of the items, with simple and efficient designs that can be reused as storage around the house. Ankarlid says, “With the bottles, we should basically have a defined second purpose. It could be used in the bathroom [or] kitchen or so on and so forth.”

This is a piece of the sustainability puzzle that A Good Company wants to support other companies with too. Ankarlid and his team worked closely with their supplier to develop the durable and environmentally friendly [Stone Paper shipping material](#), now offered at cost price to all other ecommerce companies interested in becoming more sustainable. The team has helped 10 other brands with packaging so far, with another 10 in the pipeline.

Climate change is the defining challenge of our era, and the actions taken by A Good Company pave the way for other brands to embed sustainability into everything from product sourcing to shipping options to packaging materials.

“

We see a massive trend in consumers who are more and more enlightened. Our top-read pages include our emission reports and those that relate to our philosophy.

Anders Ankarlid
CEO, A Good Company



How Shopify can help

Build sustainable practices into your shipping strategy

Shopify is committed to being a positive contributor to building a more sustainable future for commerce. Part of that commitment is to offer solutions that help merchants build more sustainable practices. We recently worked with leading scientific experts Carbon Direct on a [guide to global transportation decarbonization](#), which will inform our own efforts and is intended to support other businesses as well.

Beyond this, Shopify offers a range of solutions that can help businesses in the right direction:

- Start small by offering an optional carbon offsetting add-on at checkout with [Shop Pay](#).
- Download the [Offset app](#) to go carbon neutral. Offset calculates the carbon emissions for each of your shipments, and then charges you to offset those emissions by contributing to carbon offset initiatives through Pachama.
- The closer your inventory is to your customer, the less you or they have to rely on carbon-heavy distribution methods. Where possible, emphasize low-carbon alternatives like walking or cycling when offering [local pickup](#) and [delivery](#).
- Many Shopify Partners are committed to making commerce more sustainable. For instance, Australian Shopify shipping partner [Sendle](#) is a certified B Corp and carbon-neutral company committed to reducing the carbon footprint of the fulfillment industry.

Learn more about Shopify's Sustainability Fund →

TREND 3

Customers choose to shop with brands that are transparent around delivery times

Clear communication will help set expectations and retain new customers during a period of high distrust and data legislation changes

KEY TAKEAWAYS

Customers expect fast and free shipping

Shoppers have been conditioned to expect fast, free, on-time delivery and will abandon their carts if it's not available.

Consumers want access to delivery timelines at checkout

Customers say estimated delivery times are the top thing they look for before purchasing.

Brands are making shipping more transparent

Merchants plan on improving transparency into shipping and deliveries in 2022.

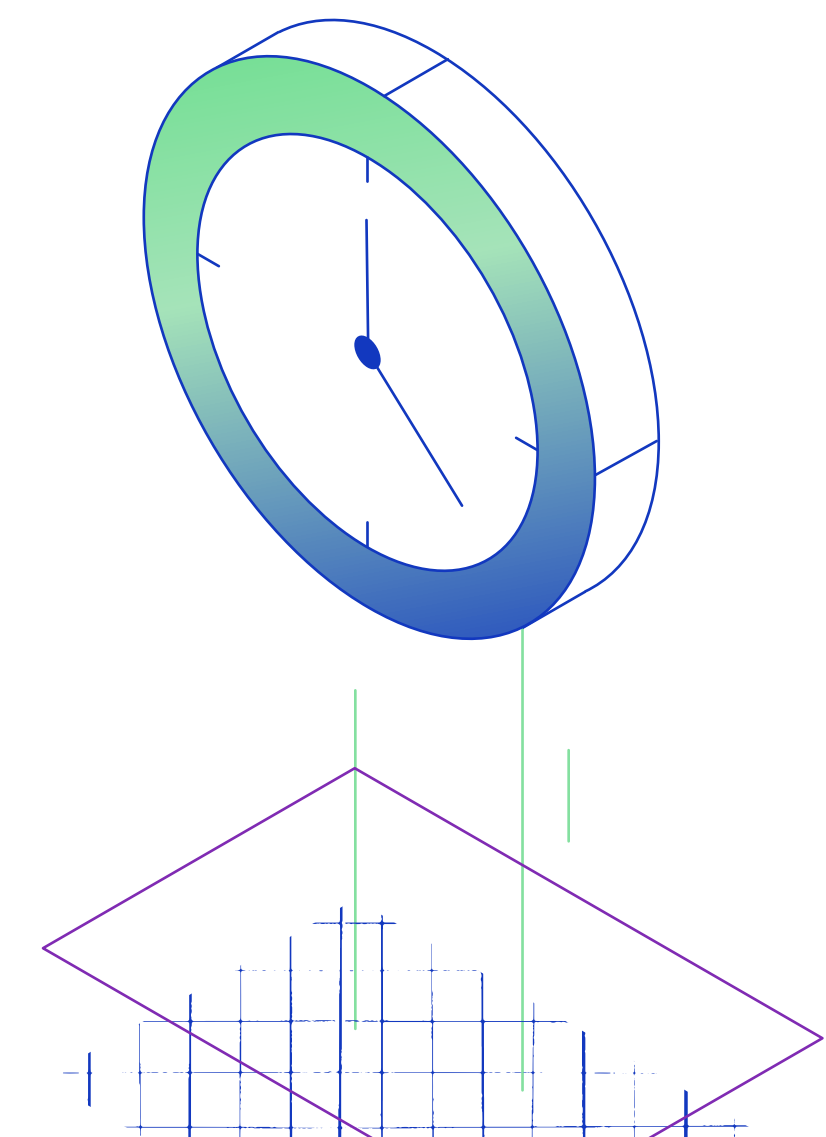

Higher-than-ever delivery expectations are colliding with the reality of fulfillment challenges

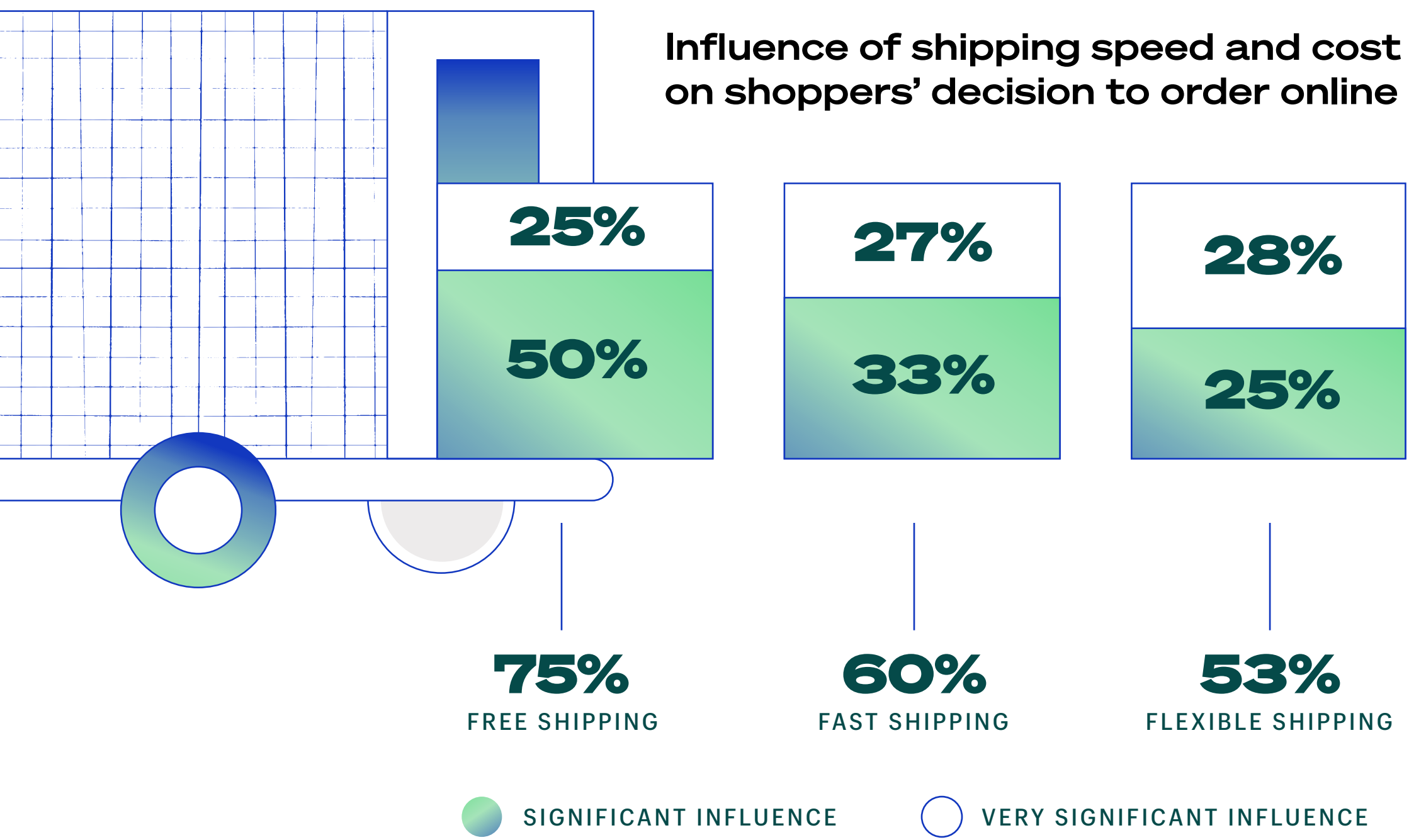

Sourced from Shopify eCommerce Market Credibility Study, 2021

There are more new online shoppers than ever before, with 90 million more digital buyers¹⁸⁸ today than in 2020. And thanks to industry leaders, they've already been conditioned to expect fast, free, on-time delivery. According to our research, free shipping continues to have a significant influence on purchasing for 75% of global shoppers,¹⁸⁹ with 58% of people expecting free next-day delivery.

In 2021, 69% of all Shopify merchants offered free shipping, the same as in 2020.¹⁸² That much hasn't changed. What has changed is that free delivery isn't enough. A customer's trust in a brand can deteriorate quickly if brands aren't able to fulfill their delivery promise. A 2020 survey found that when packages are delayed but consumers aren't informed, 69.7% of customers¹⁸³ would be less likely to shop with that retailer again.

Percentage of shoppers that abandoned a purchase because estimated shipping time was too long

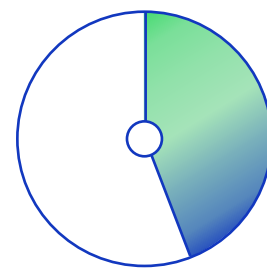

37%
NORTH AMERICA

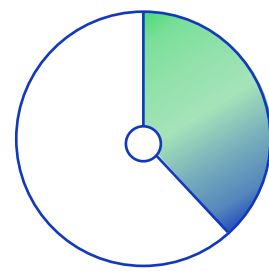

32%
EUROPE, MIDDLE EAST, AND AFRICA

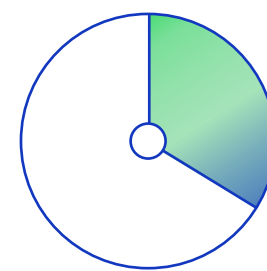

28%
ASIA PACIFIC

Sourced from Shopify eCommerce Market Credibility Study, 2021

Lack of clarity around shipping loses sales. In the last year alone, 32%¹⁸⁴ of customers have abandoned their carts because “the estimated shipping time was too long,” and 22%¹⁸⁵ because “there was no guaranteed delivery date.” Even brand loyalty won’t stop them from walking away. In 2020, 56% of consumers¹⁸⁶ shopped with a new retailer because “they could not get timely delivery from their regular retailer.”

This coincides with a moment in time when customer retention is more important than ever, with recent and [upcoming privacy changes](#) (including Apple’s iOS 14 update and Google Chrome’s phase-out of third-party cookies) limiting the collection of data and making customer acquisition increasingly difficult.

Last year we said that the fulfillment mandate of brands should be to provide “fast, free, sustainable, and branded” shipping.¹⁸⁷ This year, we’re adding one more must-have quality to the list: dependable.

The new equation for shipping success

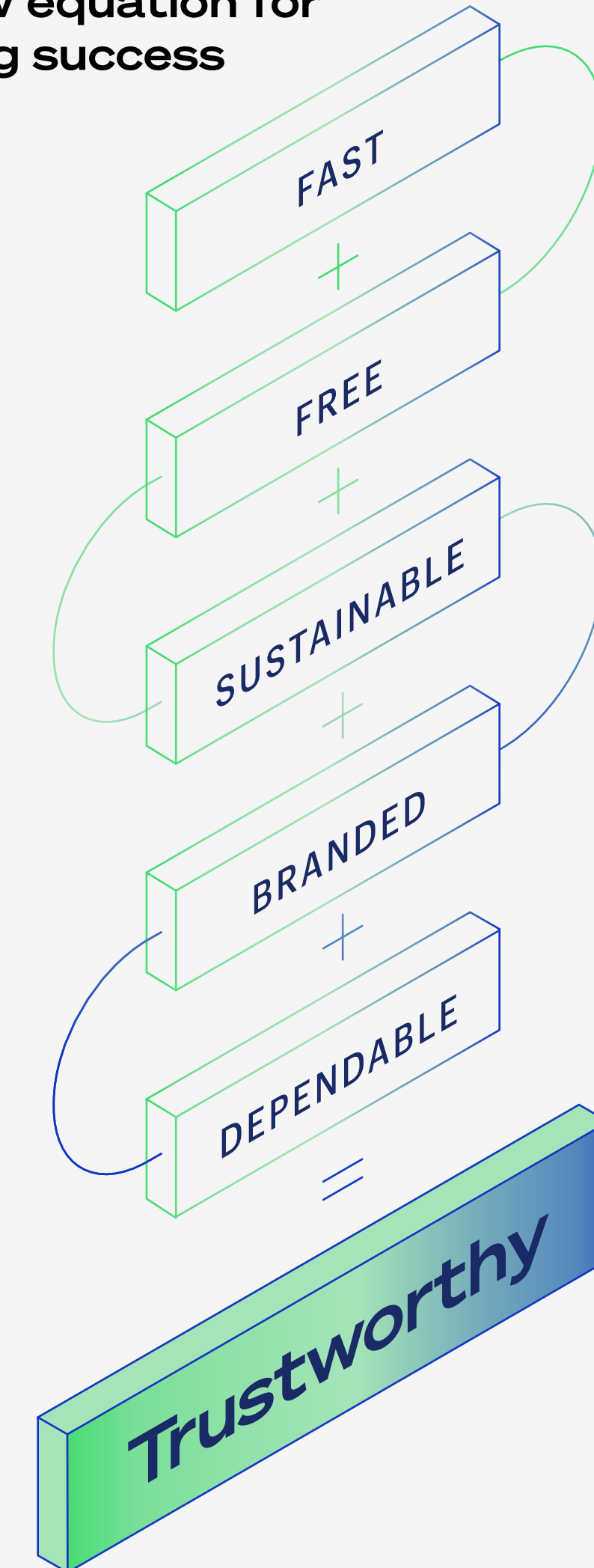

Inaccurate delivery times can jeopardize customer relationships at a time when retention is paramount

45%

of shoppers are looking for businesses who clearly show anticipated delivery times

Shopify eCommerce Market Credibility Study, 2021

At this critical moment, winning over first-time buyers and turning them into lifetime customers is of the foremost importance—and meeting delivery promises is key to retention. Around 45% of shoppers are actively “looking for businesses who clearly show anticipated delivery times.”¹⁹⁰

But high consumer expectations coupled with supply chain bottlenecks make this easier said than done. Getting packages to customers on time when there simply aren't enough drivers to complete last-mile deliveries¹⁹¹ comes at a cost. Due to an increase in national and cross-border volume orders caused by online shopping, delivery agents like UPS and FedEx have instituted increased surcharges¹⁹² on expediting shipping, with peak periods lasting longer than ever before.

“[It's created] a scenario where the brands are going to have to figure out how to get a consumer comfortable with a longer shipping time, whether that's a discount or charging for [expedited] shipping,”

Sharon Goldstein
CEO of LimeSpot

Being fully transparent about delivery times is an opportunity to win over and retain new customers

In 2022 the opportunity to build trust and transparency through delivery-related communications will be key to creating long-term relationships resilient enough to withstand the industry's continued challenges. Customers report that two of the most important qualities when they shop online are cost and estimated time of delivery: 74% of consumers¹⁹³ are influenced by price, while 68% are influenced by estimated time of delivery.

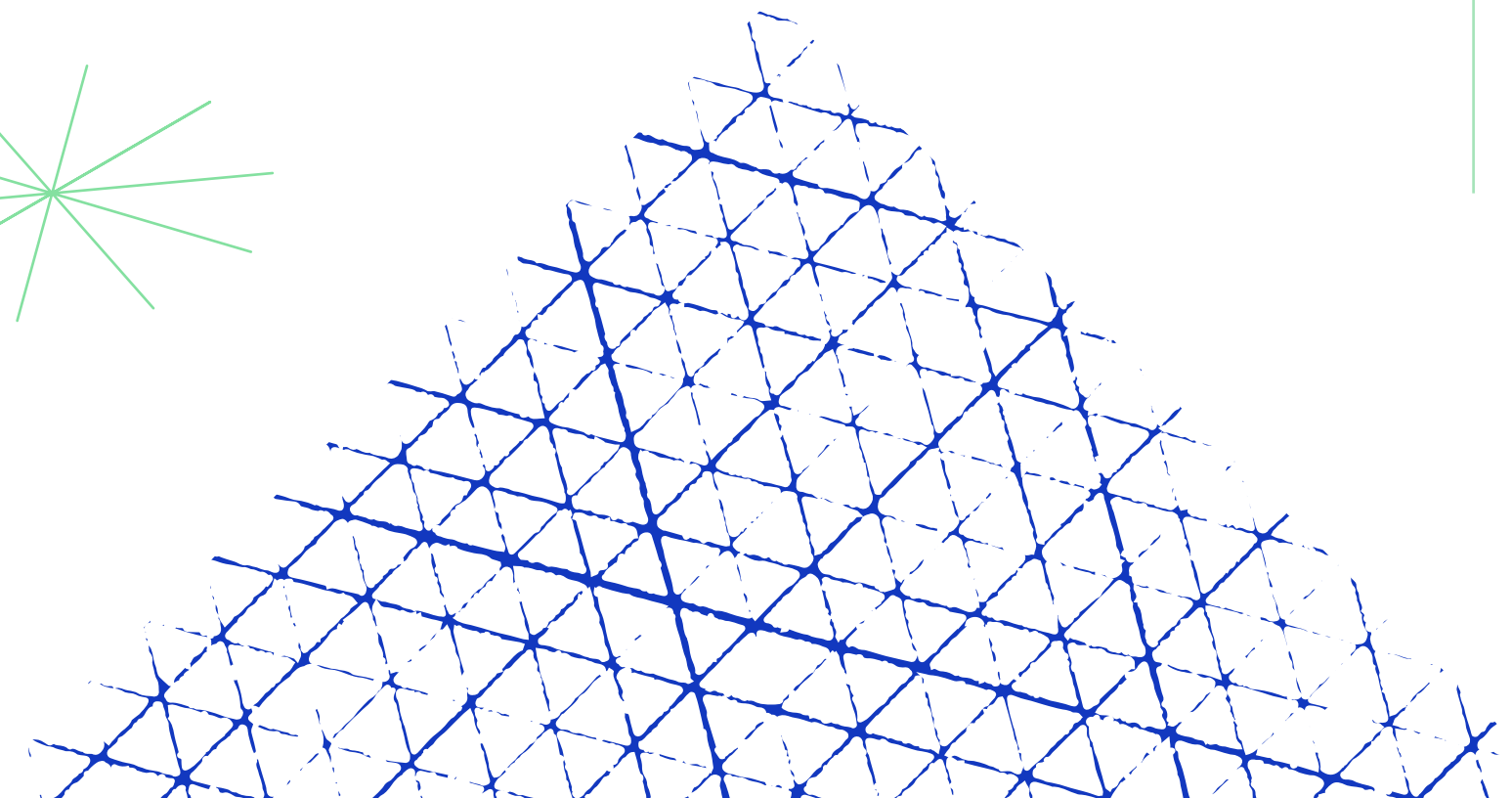
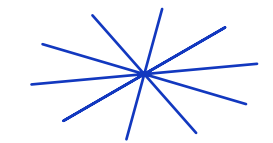
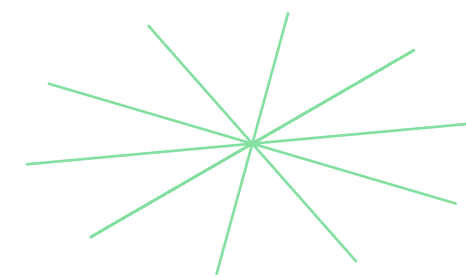

As unboxing becomes as important as the retail experience, customers are seeking out proactive communication, regular shipping updates, and delivery options that suit their needs.

For example, 35%¹⁹⁴ are choosing shipping options like curbside pickup or click and collect to receive their orders in time, which can also have a positive impact on lifetime customer value and average order value. Research conducted by Shopify in 2020 found that online shoppers who chose in-store pickup or delivery will spend up to 23% more,¹⁹⁵ while those who choose local pickup have a 13%¹⁹⁶ higher conversion rate.

Currently, 49% of the brands¹⁹⁷ we surveyed are investing in not just their delivery practices, but transparency with their delivery promises, like sharing when an order is prepared and shipped. Providing a friction-free and more transparent purchasing experience will contribute to lower cart abandonment, improved customer trust and retention, and lower overhead operating costs.

What consumers find most valuable when searching for and buying products online

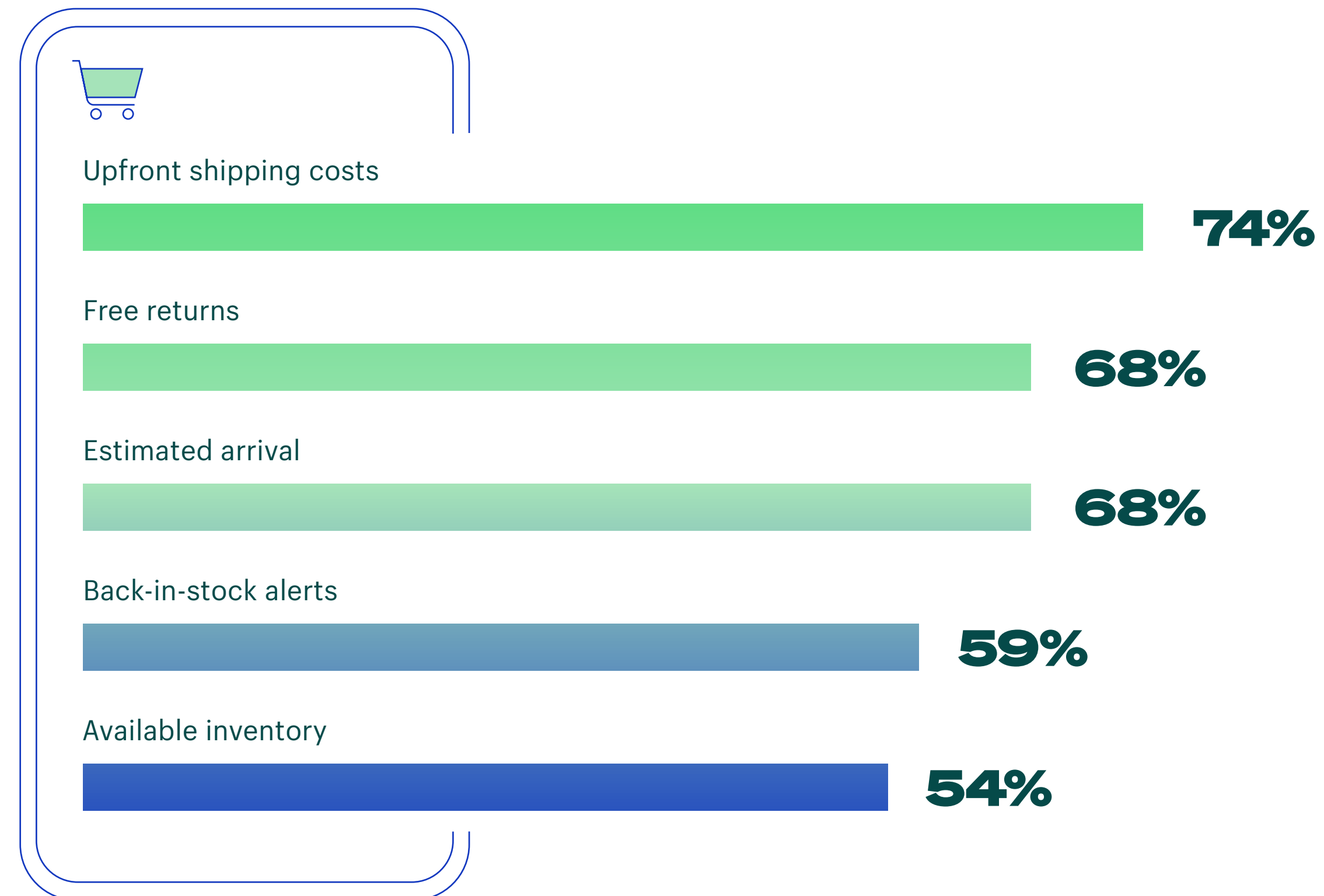

Sourced from Shopify eCommerce Market Credibility Study, 2021

RECOMMENDATIONS

How to overcome shipping challenges in 2022



RECOMMENDATION 1

Manage customer expectations with clear delivery timelines



Make final costs and delivery times clear upfront

Knowing upfront how much an order will cost to ship (including taxes and fees) is the number one consumer consideration when searching for or buying products online. Fulfill this need by communicating customer duty and tax obligations as part of the ordering process, avoiding any nasty surprises later on.

Consider using a space on your online store, like a banner that advises customers when they might receive their order, even before they've reached the checkout page. A buyer can then decide if the timeline is within their expectations.



Share an estimated arrival time

Including estimated arrival times is one way to establish trust, even if it means communicating to customers that wait times are longer than usual. Consumers are increasingly open to supporting brands, provided they're delivering accurate information about shipping times. In fact, 66% of shoppers¹⁹⁸ are already generally aware that supply chain delays are likely to impact their orders.

Two-thirds

of shoppers are generally aware that supply chain delays are likely to impact their orders

Shopify eCommerce Market Credibility Study, 2021

RECOMMENDATION 1



Over-communicate during shipping

Once an order is placed, your customer might not understand the difference between shipping and processing times—nor should they need to. It's up to your business to clearly communicate when a product is going to leave a warehouse and when it's going to arrive at the customer's doorstep.

Don't expect customers to check tracking numbers on a third-party carrier site after they place their order. Instead, use post-purchase automation tools to send regular email or SMS updates when a product is picked, packaged, and shipped, as well as when they can expect to receive it.

Just as critically, time your post-purchase emails for when a customer receives their package. Asking a customer for feedback on a product they haven't received can magnify frustrations. These frequent and well-timed communications give buyers confidence in a merchant, even in the case of shipping delays.



Keep customer service at the heart of your process

A strong and responsive customer service team should sit at the heart of the experience. This helps connect the dots among expectations, merchant promises, and the vast system of order and inventory management happening behind the scenes. Chatbots can support your team, but at the end of the day, you'll need to have real people who are capable of proactively responding to—and resolving—issues like unexpected shipping delays.

“Consumers are starting to adapt to the new world of how long it takes to receive a package. No brand in the world has any control right now over carriers, so I think you just need to be overly communicative with your customers around shipping delays. For us, it's been just managing expectations throughout the entire process.”

Kevin Gould

Co-founder, Glamnetic

RECOMMENDATION 2

Offer fulfillment options that match your market's expectations



In the midst of uncertainty, it's important to remember that people are reasonable and willing to adjust their shopping patterns. Almost half¹⁹⁹ are committed to making purchases earlier to guarantee delivery by a set date.

“Recently, smaller brands especially have shifted back to the five- to seven-day shipping periods. Previously, we would've been like, ‘Wow, that's a no-go. How can you compete in the age of Amazon?’” says Megan Chen, ecommerce senior investment associate at Encore Consumer Capital. “But they've been proactively communicating to their consumers and saying, ‘Hey, we're a small brand and we have to do this to stay alive, especially in the mess that was COVID.’”

In the end, a good shipping strategy doesn't mean offering every available shipping option: It's about finding a balance between what's affordable, realistic, and aligned with the needs of customers. Depending on the category of goods that you sell, “free” can be once you hit a \$50 free shipping threshold, and “fast” can also be a relative term, with 44% of customers²⁰⁰ expecting deliveries to take a week or longer to arrive. It can also depend on your target demographic. Millennials and Gen Z shoppers are up to three times more likely²⁰¹ to want and pay for expedited shipping, compared with older age groups.

“It's really important for brands to know their consumers. For example, are you selling instant gratification products? Do consumers need them yesterday? Or are they okay to wait it out for the next three days?” advises Saujanya Shrivastava, director of products, shipping at Shopify. “Understanding what the customer is expecting is really important to set your shipping strategy.”

MERCHANT SPOTLIGHT

How Manly Bands beats supply chain delays to get rings into the hands of customers

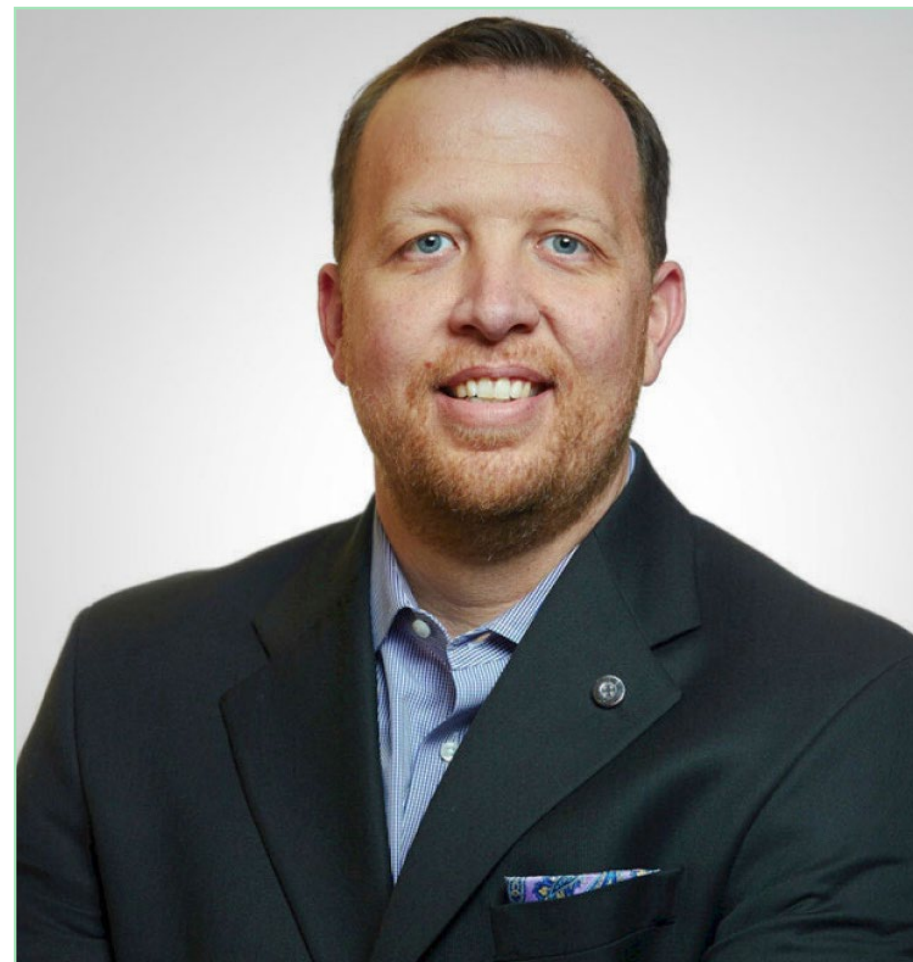

“

Give the customer options to choose their own destiny, and ensure they can track progress until delivery is complete.

Eric Farlow
Chief Operating Officer, Manly Bands

Manly Bands exists to help every person find the wedding band that is unique to them. So what happens when international supply chain disruptions get in the way of products that are needed for one of the biggest days of a customer's life?

Manly Band chief operating officer Eric Farlow discusses the challenges the company has faced this year: “Shipments of ring boxes, branded boxes, and other supplies have been delayed for months at port. We have had to diversify our portfolio of suppliers so that we can still meet our commitments to our customers.”

Supplier diversification isn't an overnight fix, and Manly Bands has had to air freight orders—which can increase the cost threefold. Sea shipment planning that used to be done two to three months in advance has been revised up to accommodate five to six months' lead time.

MERCHANT SPOTLIGHT

The team has also started to invest in 3PLs to fulfill orders closer to customer locations. Farlow says, “As it is our priority to make sure the customer is 100% satisfied, we have taken on the shipping challenges at our warehouse instead of the customer. For this reason, we have set up 3PL relationships allowing us to fulfill orders closer to the customer. By doing this, we have found that we have more control over our shipping commitments.”

Manly Bands has air freighted fulfillment supplies, diversified partners, and invested in a 3PL network to mitigate the impact of delivery delays. When delays do occur, the company focuses on strong communication and customer empowerment.

“Customer commitments are extremely important since their ring needs to arrive before the biggest day of their lives. We have mitigated any delays by over-communicating expectations prior to the sale so that the customer can shop in confidence, offering multiple shipping options so they can choose the best fit for them, and maintaining a best-in-class customer service organization to communicate post sale up until delivery.”

This strategy has proven to be successful, with the brand’s customer satisfaction score holding steady at 97.9% throughout 2021.

A large graphic showing the number 97.9% in green and blue colors. The '9' and '7' are green, the decimal point and '9' are light green, and the percentage sign is blue.

**customer satisfaction score
in 2021 by Manly Bands**

How Shopify can help

Create transparency throughout the checkout experience

- Shopify's Online Store allows you to add sections to the product page that clearly [articulate shipping and return policies](#), making it easy to set delivery expectations from the moment your customer starts browsing straight through to checkout.
- With [shipping speeds](#), you can create transparent checkout experiences that improve your customer experience and reduce cart abandonment.

Make it easy for your customers to track their orders

- Automate [order notification emails](#) and SMS to let your customers know when their orders have been received, packaged, and sent out for delivery.
- Through the [Shop app](#), your customers can automatically access up-to-the-minute tracking information for their order, and anticipate or mitigate delays.
- With Shopify, your customer service team can easily check the [order timeline](#) to address any questions that come in about an order.

Take the hassle out of the returns process

- Shopify's platform helps you create a painless [return experience](#) for your customers. You can easily initiate returns, automatically email customers a return label, track progress, and refund customers.
- You can also automate notifications to keep track of ongoing order refunds and returns.

Ship orders to customers for less with Shopify Shipping →

ENDNOTES

- 1 Shopify eCommerce Market Credibility Study, a commissioned survey conducted by Forrester Consulting on behalf of Shopify, September 2021
- 2 [2020 Zeno Strength of Purpose Study](#), Zeno Group
- 3 [Business of Sustainability Study](#), GreenPrint
- 4 [Global social commerce market size, 2021-2026](#), Statista
- 5 [Mastercard New Payments Index 2021](#), Mastercard
- 6 [Turbulent waters, A perfect storm for container shipping](#), The Economist
- 7 [Predicts 2020: Marketers, they're just not that into you](#), Gartner
- 8 [The Rise of the Purpose-Led Brand](#), Accenture
- 9 Shopify eCommerce Market Credibility Study, 2021
- 10 Shopify eCommerce Market Credibility Study, 2021
- 11 Shopify eCommerce Market Credibility Study, 2021
- 12 Shopify eCommerce Market Credibility Study, 2021
- 13 Shopify eCommerce Market Credibility Study, 2021
- 14 [World Wildlife Federation](#)
- 15 [Retail e-commerce sales worldwide from 2014 to 2024](#), Statista
- 16 Shopify eCommerce Market Credibility Study, 2021
- 17 [Digital 2021 October Global Statshot Report](#), Datareportal
- 18 Shopify eCommerce Market Credibility Study, 2021
- 19 [Buying Consumer Data? Tread Carefully](#), Harvard Business Review
- 20 [The Marketer's Toolkit 2021](#), WARC
- 21 [The Marketer's Toolkit 2021](#), WARC
- 22 [Inside Google Marketing: 3 rules driving our holiday retail strategy](#), Think with Google
- 23 [What impact does brand equity have on profit?](#), Investopedia
- 24 [Performance branding and how it is reinventing marketing ROI](#), McKinsey
- 25 [The art of balancing long-term brand marketing and short-term demand marketing](#), The Drum
- 26 [Share of search can predict market share](#), WARC
- 27 [The Marketer's Toolkit 2021](#), WARC
- 28 [Smart Speakers and Screens](#), Strategy and Analytics
- 29 [Connected TV advertising spend in the United States](#), Statista
- 30 [Why video games are the next retail frontier](#), ModernRetail
- 31 Shopify eCommerce Market Credibility Study, 2021
- 32 [The Rise of the Purpose-Led Brand](#), Accenture
- 33 Shopify eCommerce Market Credibility Study, 2021
- 34 [Personal information protection law of the People's Republic of China](#), The National People's Congress of the People's Republic of China, 2021
- 35 [Lei no 13.709, de 14 de agosto de 2018](#), Presidency of the Republic General Secretariat Sub - Head of Legal Affairs, 2018
- 36 [CCPA regulations](#), State of California Department of Justice
- 37 [Irish inquiries into big tech too slow, campaigner complains to EU ombudsman](#), The Irish Times, 2021
- 38 Shopify eCommerce Market Credibility Study, 2021
- 39 [An updated timeline for Privacy Sandbox milestones](#), The Keyword (Google)
- 40 Shopify eCommerce Market Credibility Study, 2021
- 41 Shopify eCommerce Market Credibility Study, 2021
- 42 [Q: The trick to effective personalization? A: Don't do personalization](#), Gartner
- 43 Shopify eCommerce Market Credibility Study, 2021
- 44 Shopify eCommerce Market Credibility Study, 2021
- 45 [The State of Community Management](#), Community Roundtable
- 46 [Brand Community](#), JSTOR
- 47 Shopify eCommerce Market Credibility Study, 2021
- 48 [NFT sales surge to \\$10.7 bln in Q3 as crypto asset frenzy hits new highs](#), Reuters
- 49 [Value of social commerce sales worldwide from 2020 to 2027](#), Statista
- 50 [Why Small Businesses Could Benefit from the Launch of Facebook Shops](#), eMarketer
- 51 [Retail Social Commerce Sales in China vs. the US, 2021](#), eMarketer
- 52 [Six Ways to Win 350 Million Southeast Asian Digital Consumers](#), Bain & Company
- 53 [Global Social Media Stats](#), DataReportal
- 54 [Nearly 1 in 3 US Facebook users will buy via the platform this year](#), eMarketer
- 55 [Instagram "no longer a square photo-sharing app," says company head](#), Hootsuite
- 56 Shopify eCommerce Market Credibility Study, 2021
- 57 Shopify eCommerce Market Credibility Study, 2021
- 58 [Global Ecommerce Explained: Stats and Trends to Watch in 2021](#), Shopify Plus
- 59 [A New Era in Retail and Ecommerce is Emerging](#), Insider Intelligence
- 60 [Digital 2021 October Global Statshot Report](#), Datareportal
- 61 Shopify eCommerce Market Credibility Study, 2021
- 62 Shopify eCommerce Market Credibility Study, 2021
- 63 Shopify eCommerce Market Credibility Study, 2021
- 64 Shopify eCommerce Market Credibility Study, 2021
- 65 [It's showtime! How live commerce is transforming the shopping experience](#), McKinsey Digital
- 66 [QVC Live Stream](#), YouTube
- 67 Shopify eCommerce Market Credibility Study, 2021
- 68 [What's next for YouTube, from Advertising Week New York](#), Ads & Commerce Blog (Google)
- 69 [Marketing Attribution: Seeing the Customer Journey More Clearly](#), Shopify Blog
- 70 [National Customer Foot Traffic Report](#), Adentro
- 71 Shopify eCommerce Market Credibility Study, 2021
- 72 Shopify eCommerce Market Credibility Study, 2021
- 73 Shopify eCommerce Market Credibility Study, 2021
- 74 [Data-driven workforce management for a work-from-anywhere world](#), Forbes
- 75 Shopify eCommerce Market Credibility Study, 2021
- 76 Shopify eCommerce Market Credibility Study, 2021

77	Shopify eCommerce Market Credibility Study, 2021	92	Shopify eCommerce Market Credibility Study, 2021	109	Retail workers are fed up and rage-quitting, and the tight labor market could help them score the better pay and benefits they've demanded for years , Insider	124	Unclogging The Ports Will Not Fix The Supply Chain's Even Bigger Trucking Crisis , Forbes	139	Logistics Real Estate and E-Commerce Lower the Carbon Footprint of Retail , Prologis
78	Shopify eCommerce Market Credibility Study, 2021	93	Shopify eCommerce Market Credibility Study, 2021	110	U.S. job openings hit record high as employers struggle to find workers , Reuters	125	Panic Ordering by Retailers is Making the Supply Chain Crisis 'Even Worse' , CNN	140	Supply Chain Crisis Will Leave Permanent Scar, UPS Warns , Financial Times
79	National Customer Foot Traffic Report , Adentro	94	Shopify eCommerce Market Credibility Study, 2021	111	UK employers face worst shortage of job candidates on record - REC , Reuters	126	Just Get Me a Box': Inside the Brutal Realities of Supply Chain Hell , Bloomberg	141	Shopify eCommerce Market Credibility Study, 2021
80	UK: retail footfall YoY change by location 2021 , Statista	95	Shopify eCommerce Market Credibility Study, 2021	112	Shopify eCommerce Market Credibility Study, 2021	127	CEO Dialogue: Perspectives on Reimagining Industrial Supply Chains , McKinsey	142	Shopify eCommerce Market Credibility Study, 2021
81	Then & Now: Urban Population Worldwide , Statista	96	Shopify eCommerce Market Credibility Study, 2021	113	Shopify eCommerce Market Credibility Study, 2021	128	Out of Stock , Vox Explained	143	Internal Shopify data
82	68% of the world population projected to live in urban areas by 2050, says UN , United Nations	97	Shopify eCommerce Market Credibility Study, 2021	114	Retailers are betting on wage hikes, perks to woo workers ahead of the holidays. Will it work? , Retail Dive	129	Shopify eCommerce Market Credibility Study, 2021	144	Cloud Computing in SCM: Cloud Integration & Organisational Impact , Reuters Events
83	Shopify eCommerce Market Credibility Study, 2021	98	Shopify eCommerce Market Credibility Study, 2021	115	Shopify eCommerce Market Credibility Study, 2021	130	Big Retailers Book Pricey Private Cargo Ships in Holiday Scramble , NBC	145	Preparing Business for the Digital Supply Chain! Oracle Interviews Mike Mortson! , Supply Chain Game Changer
84	Evolution of shopping preferences and behaviors, Angus Reid Group commissioned by Shopify, 2021	99	Shopify eCommerce Market Credibility Study, 2021	116	Shopify eCommerce Market Credibility Study, 2021	131	Shopify eCommerce Market Credibility Study, 2021	146	The 'Zero Inventory' Solution , Business of Fashion
85	How Gen Z's concern with emotional health fuels retail growth and culture , Kearney	100	Shopify eCommerce Market Credibility Study, 2021	117	Shopify eCommerce Market Credibility Study, 2021	132	Shopify eCommerce Market Credibility Study, 2021	147	Turn Your Retail Space into Distribution Space , Supply Chain Management Review
86	How Gen Z's concern with emotional health fuels retail growth and culture , Kearney	101	Shopify eCommerce Market Credibility Study, 2021	118	UNTUCKit and HERO partner to help online shoppers find the perfect fit , HERO	133	Click-and-Collect 2021: Buy Online, Pick-up In Store (BOPIS) Industry Trends , Business Insider	148	Micro Fulfillment Market for Grocery and General Merchandise By Technologies (AutoStore, Shuttle Based), By Warehouse Size, By Geography - Forecast to 2026 , Research and Markets
87	Shopify eCommerce Market Credibility Study, 2021	102	Shopify eCommerce Market Credibility Study, 2021	119	Shopify eCommerce Market Credibility Study, 2021	134	Smart Parcel Locker Market to Hit USD 1,630.2 Million by 2028; Rising Post and Parcel Industry to Stimulate Growth: Fortune Business Insights , Global News Wire	149	Third-party Logistics Market Size, Share & Trends Analysis Report By Service (ITM, DTM, VALs), By Transport (Roadways, Airways), By End Use (Manufacturing, Retail), And Segment Forecasts, 2021-2028 , Grand View Research
88	Number of store closures announced by selected companies in the retail and leisure sector worldwide during the first half of 2020 , Statista	103	ICSC finds over half of online shoppers use click-and-collect , ICSC	120	China's Energy Crisis is Hitting Everything from iPhones to Milk , Bloomberg	135	Succeeding in the AI Supply-Chain Revolution , McKinsey	150	Shopify eCommerce Market Credibility Study, 2021
89	Rent is cheap, vacant space is everywhere: Retailers seize the moment to open stores , CNBC	104	Shopify eCommerce Market Credibility Study, 2021	121	Just Get Me a Box': Inside the Brutal Realities of Supply Chain Hell , Bloomberg	136	Succeeding in the AI Supply-Chain Revolution , McKinsey	151	Third-party Logistics Market Size, Share & Trends Analysis Report By Service (ITM, DTM, VALs), By Transport (Roadways, Airways), By End Use (Manufacturing, Retail), And Segment Forecasts, 2021-2028 , Grand View Research
90	As store owners sign more short-term leases, landlords are taking a risky bet on the future of retail , CNBC	105	Shopify eCommerce Market Credibility Study, 2021	122	Industrial Strength Supply Chain Stress May Have Peaked Already , Bloomberg	137	Succeeding in the AI Supply-Chain Revolution , McKinsey		
91	Shopify eCommerce Market Credibility Study, 2021	106	Shopify eCommerce Market Credibility Study, 2021	123	JD Logistics Goes Shopping for Planes to Tap Air Freight Demand , Bloomberg	138	Shopify eCommerce Market Credibility Study, 2021		
		107	Shopify eCommerce Market Credibility Study, 2021						
		108	Shopify eCommerce Market Credibility Study, 2021						

- 152 [Why Retailers Like American Eagle are Buying up Supply Chain Companies](#), Modern Retail
- 153 [Find the Right Partner to Deliver your Brand](#), Shopify Plus
- 154 [An Eco-Awakening: Measuring Global Awareness, Engagement, and Action for Nature](#), The Economist
- 155 Shopify eCommerce Market Credibility Study, 2021
- 156 Shopify eCommerce Market Credibility Study, 2021
- 157 Shopify eCommerce Market Credibility Study, 2021
- 158 Shopify eCommerce Market Credibility Study, 2021
- 159 [Fashion Transparency Index](#), 2021
- 160 [How Does the Impact Index Support Sustainable Fashion?](#), Sustainability
- 161 [Can Blockchain Create a Sustainable Supply Chain?](#), Raconteur
- 162 Shopify eCommerce Market Credibility Study, 2021
- 163 [Modern Slavery Act 2018](#), Australian Government Federal Register of Legislation
- 164 [Modern Slavery](#), Gov.UK
- 165 [The California Transparency in Supply Chains Act](#), oag.ca.gov
- 166 [PO.P Second Hand: Used and Loved](#), Polarn O Pyret
- 167 [Leveraging the Value of Emotional Connection for Retailers](#), Motista
- 168 [Impact investing is Hot Right Now. Here's Why](#), MIT Management Sloan School
- 169 [The Meaning, Changing Perceptions, and Expanding Agendas](#), Get Smarter
- 170 [The Future of the Last-Mile Ecosystem](#), World Economic Forum
- 171 Shopify eCommerce Market Credibility Study, 2021
- 172 Shopify eCommerce Market Credibility Study, 2021
- 173 [Carbon Offsets Are About To Become A Huge Market](#), Forbes
- 174 [Logistics Real Estate and E-Commerce Lower the Carbon Footprint of Retail](#), Prologis
- 175 [Logistics Real Estate and E-Commerce Lower the Carbon Footprint of Retail](#), Prologis
- 176 [Logistics Real Estate and E-Commerce Lower the Carbon Footprint of Retail](#), Prologis
- 177 Shopify eCommerce Market Credibility Study, 2021
- 178 Shopify eCommerce Market Credibility Study, 2021
- 179 [Logistics Real Estate and E-Commerce Lower the Carbon Footprint of Retail](#), Prologis
- 180 [A More Sustainable Supply Chain](#), Harvard Business Review
- 181 Shopify eCommerce Market Credibility Study, 2021
- 182 [Number of Digital Buyers Worldwide from 2014 to 2021](#), Statista
- 183 Shopify eCommerce Market Credibility Study, 2021
- 184 Internal Shopify data
- 185 [COVID-19 Survey: Accurate Delivery Dates Are Key To Win Consumer Confidence](#), GetConvey
- 186 Shopify eCommerce Market Credibility Study, 2021
- 187 Shopify eCommerce Market Credibility Study, 2021
- 188 [State of Returns: New Expectations](#), Narvar
- 189 The Future of Ecommerce: Fulfillment Emerges as Competitive Differentiator, Shopify
- 190 Shopify eCommerce Market Credibility Study, 2021
- 191 [Unclogging The Ports Will Not Fix The Supply Chain's Even Bigger Trucking Crisis](#), Forbes
- 192 [UPS Rolls Out Peak Season Surcharges](#), Supply Chain 24/7
- 193 Shopify eCommerce Market Credibility Study, 2021
- 194 Shopify eCommerce Market Credibility Study, 2021
- 195 [Ecommerce Fulfillment, Free Shipping & Two-Day Delivery: How to Compete with Amazon While Increasing Profit Margins](#), Shopify
- 196 [Ecommerce Fulfillment, Free Shipping & Two-Day Delivery: How to Compete with Amazon While Increasing Profit Margins](#), Shopify
- 197 Shopify eCommerce Market Credibility Study, 2021
- 198 Shopify eCommerce Market Credibility Study, 2021
- 199 Shopify eCommerce Market Credibility Study, 2021
- 200 [State of Returns: New Expectations](#), Narvar
- 201 [Millennials and Gen Z Are Up to Three Times More Likely to Pay for Expedited Shipping, According to LaserShip's E-Commerce Shipping Survey, Conducted by Hanover Research](#), Cision PR Web